

What neurophysiology  
do I need to know?

Dominik Straumann

# Different approaches

- anatomical approach  
functions of neural structures
- phenomenological approach  
description & explanation of phenomena in  
healthy subjects & patients

# Many topics...

- frequency-dependence of the angular VOR
- acceleration & velocity steps
- velocity-to-position mechanism
- vestibular canal asymmetry
- velocity-to-position
- Alexander's law
- vestibular push-pull mechanism
- Ewald's second law & head impulses
- linear VOR
- tilt vs. translation dilemma, ocular counterroll
- Coriolis stimulation

**Let's start!**

# angular Vestibulo-Ocular Reflex (aVOR)

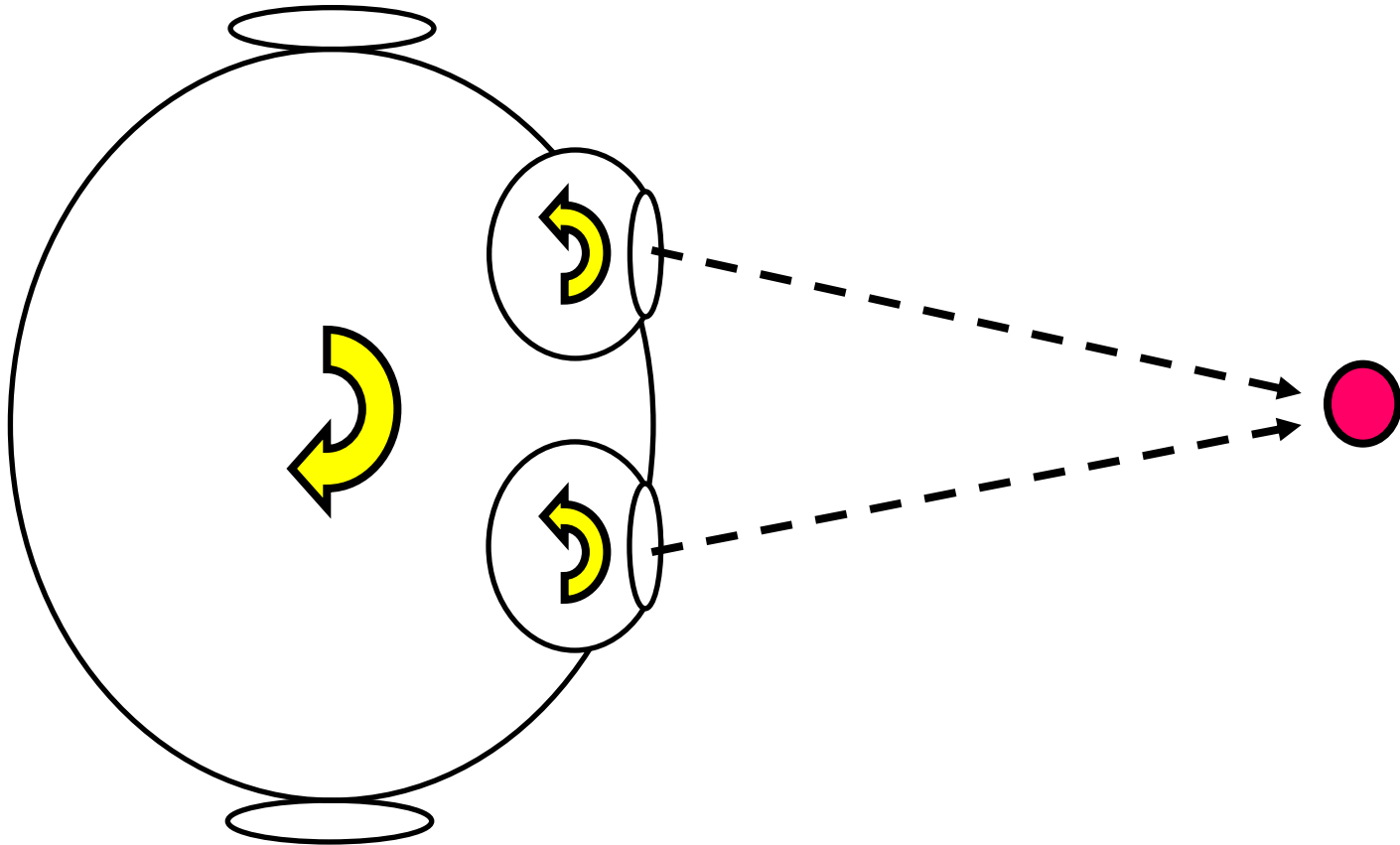

# Gaze stabilization in space

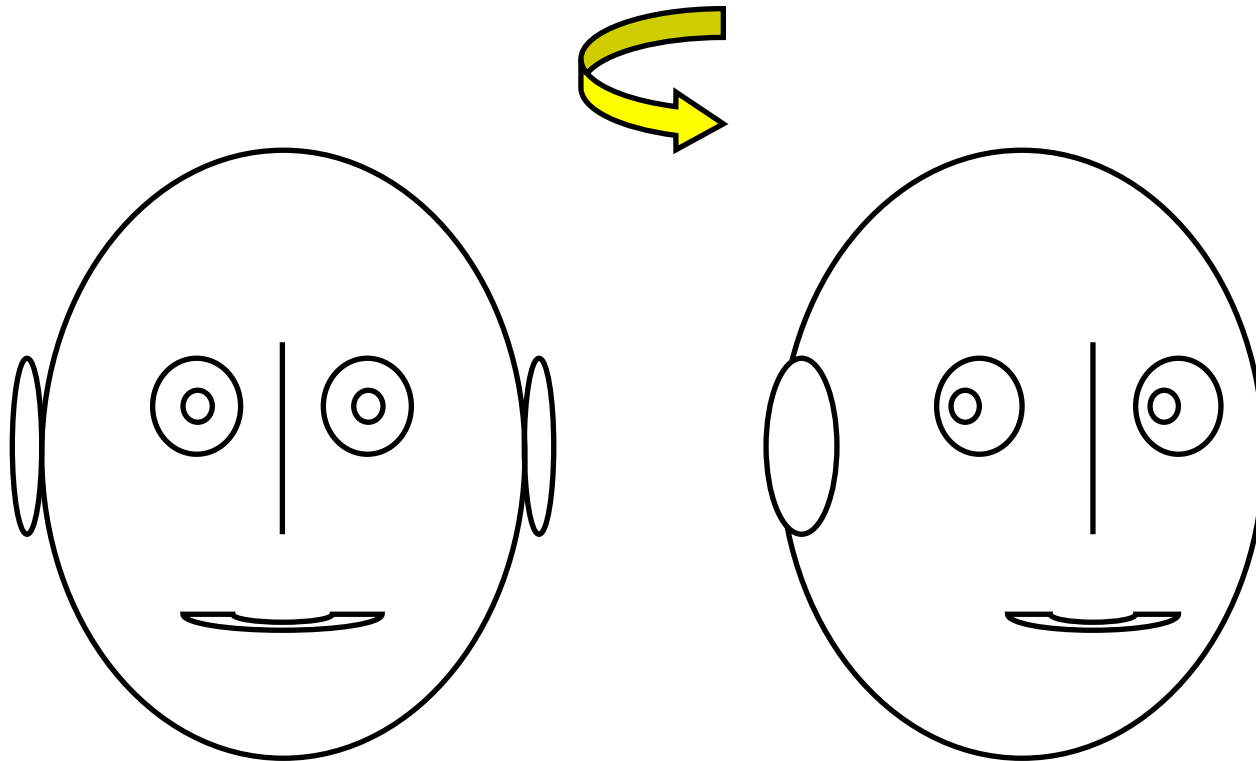

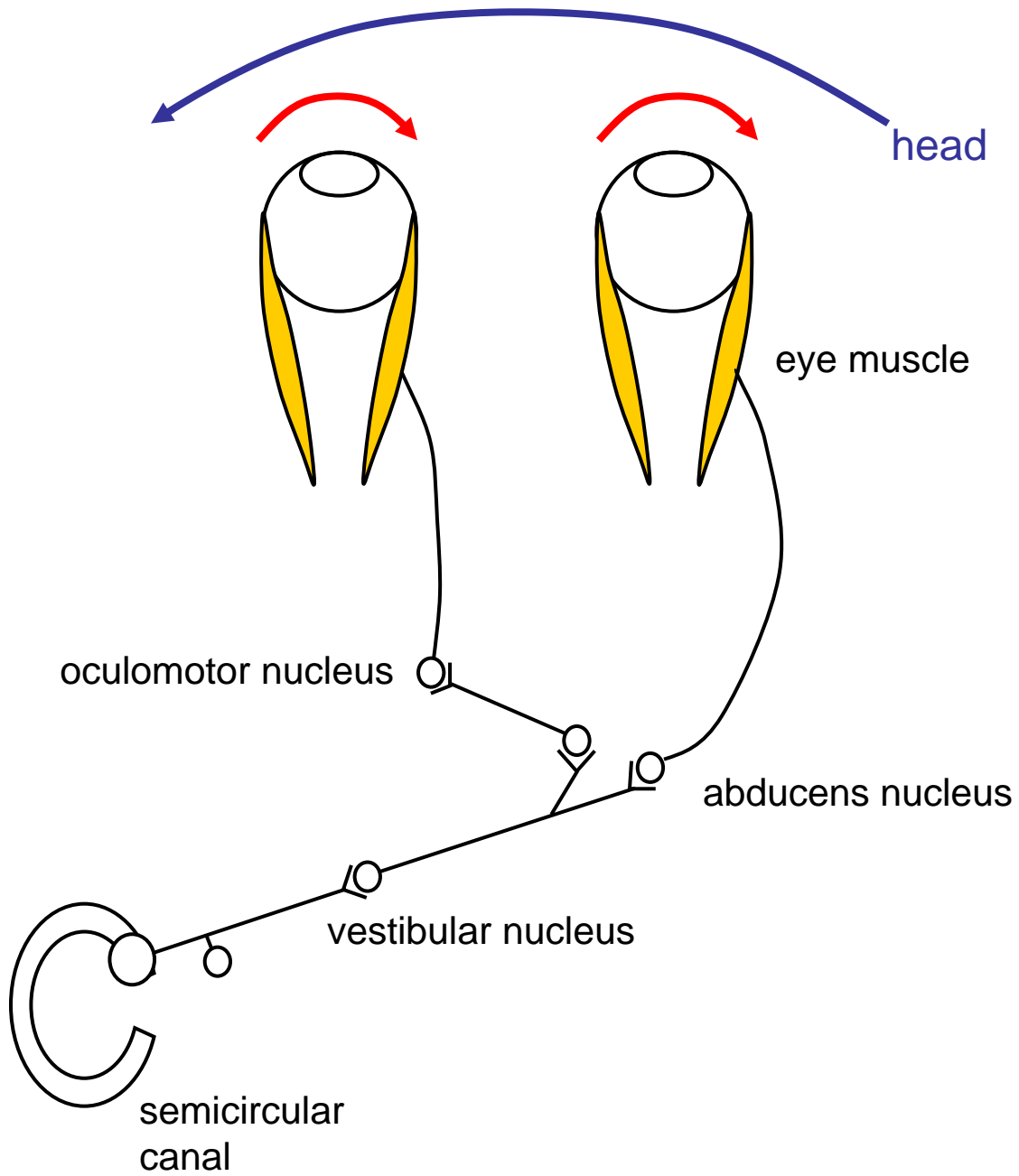

# Head, Eye, Gaze

„perfect“ VOR

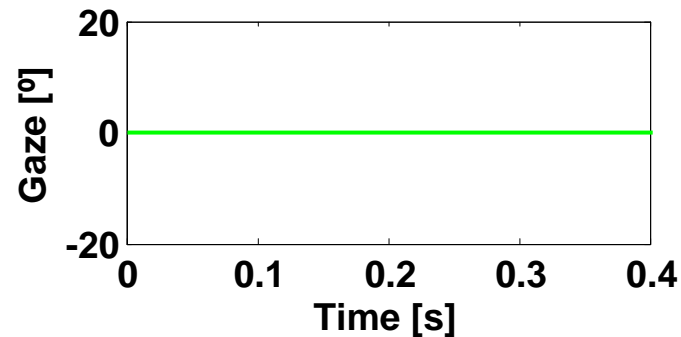
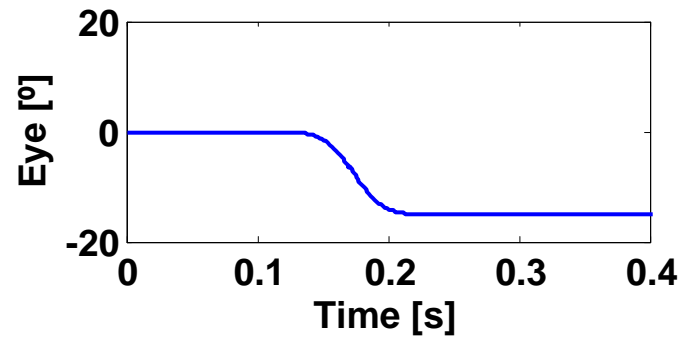
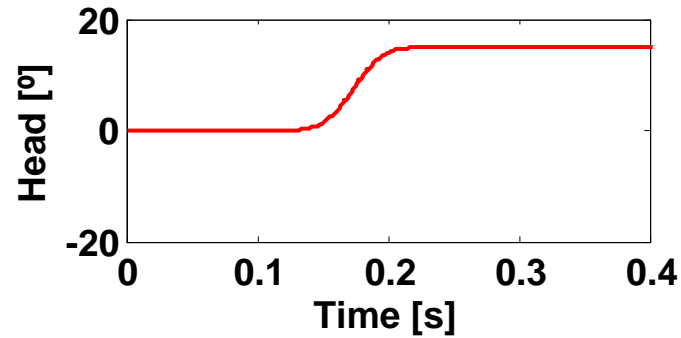

**gaze = head + eye**  
(„eye-in-space“)

# Velocity, gain

„perfect“ VOR

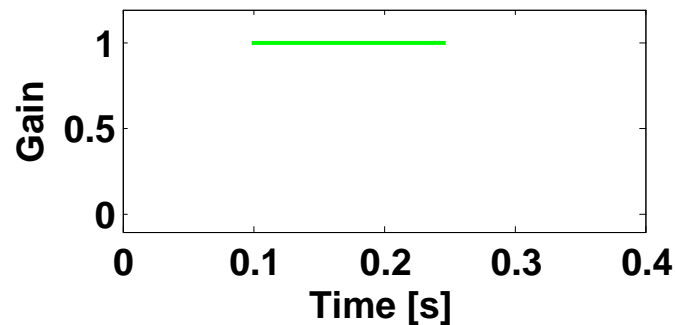
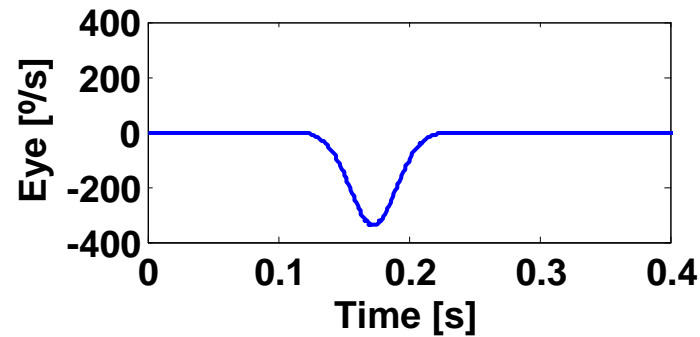
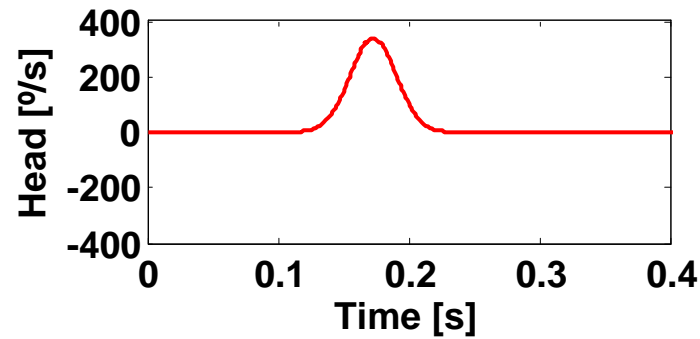

$$\text{gain} = \frac{\text{eye velocity}}{\text{- head velocity}}$$

# Frequency dependence

0.3 Hz

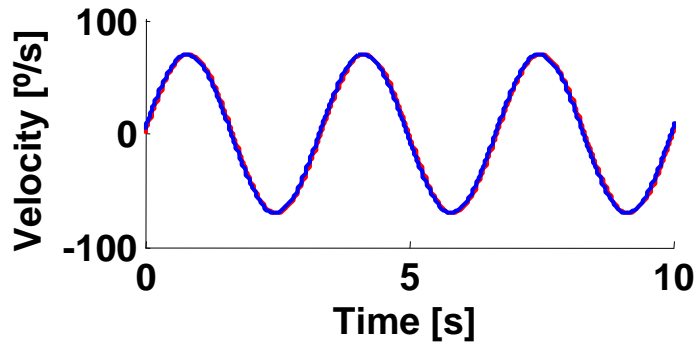

— -head  
— eye

gain  $\approx 1$   
phase  $\approx 0$

0.05 Hz

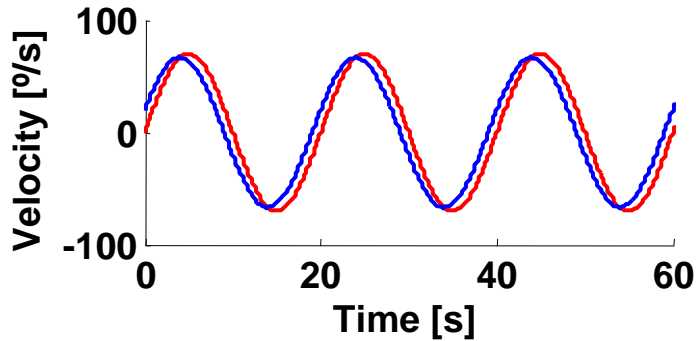

0.01 Hz

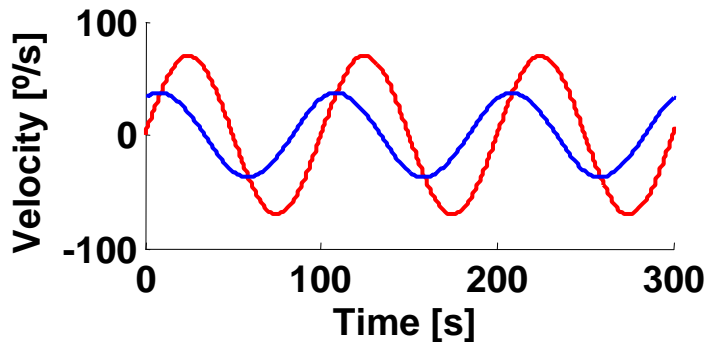

gain  $\downarrow$   
phase lead

# Bode plot



Hendrik Wade Bode  
1905-1982

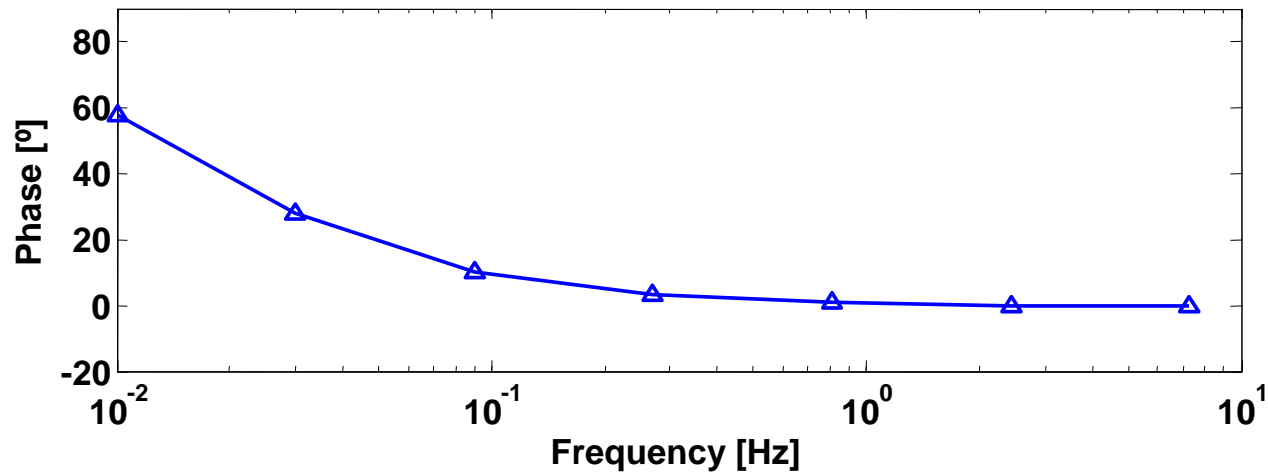
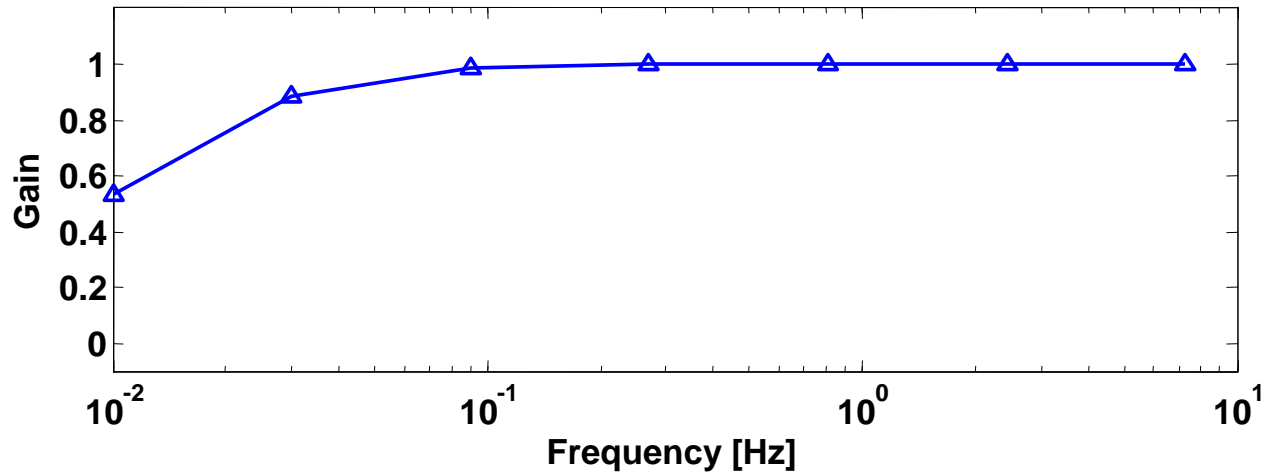

# Horizontal vestibulo-ocular reflex testing

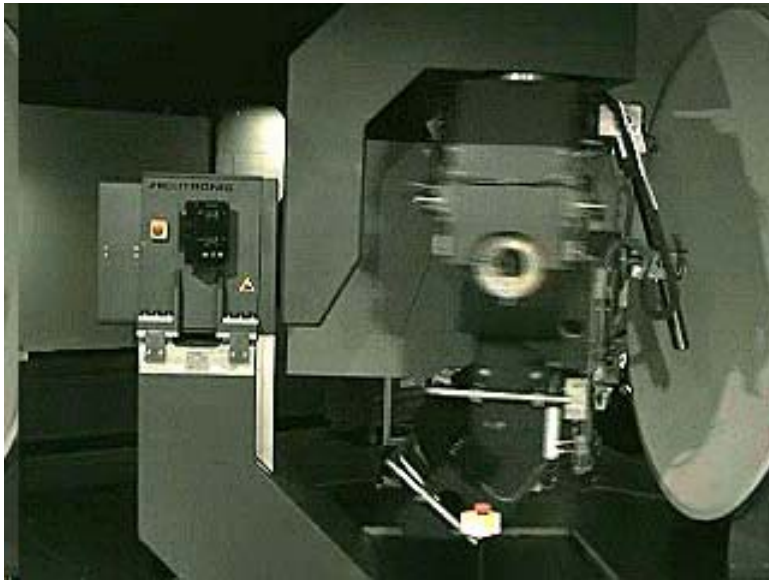

Horizontal rotation

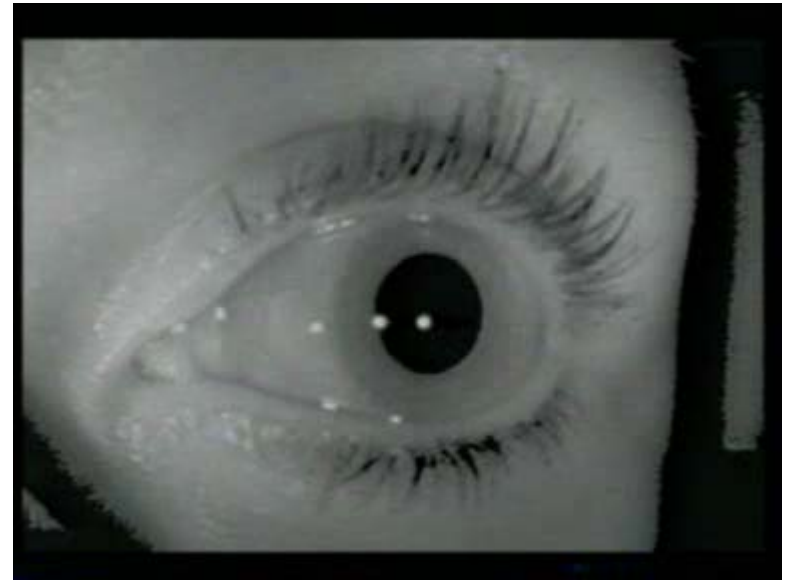

Horizontal nystagmus

# Horizontal vestibulo-ocular reflex testing

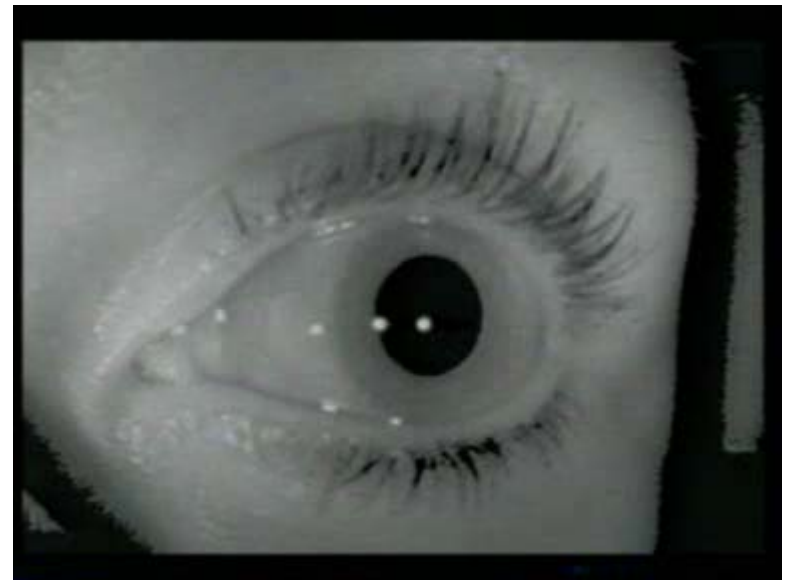
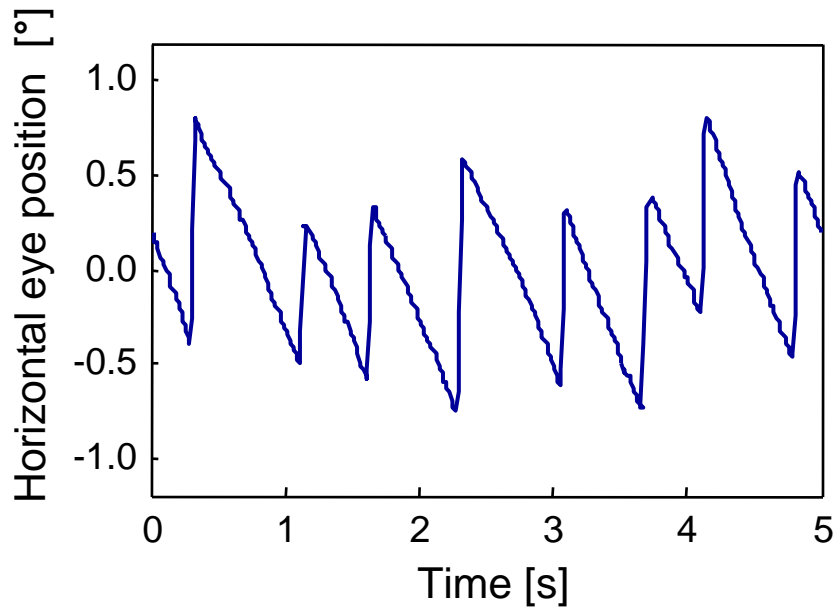

Horizontal nystagmus

# Velocity step response

in the dark!

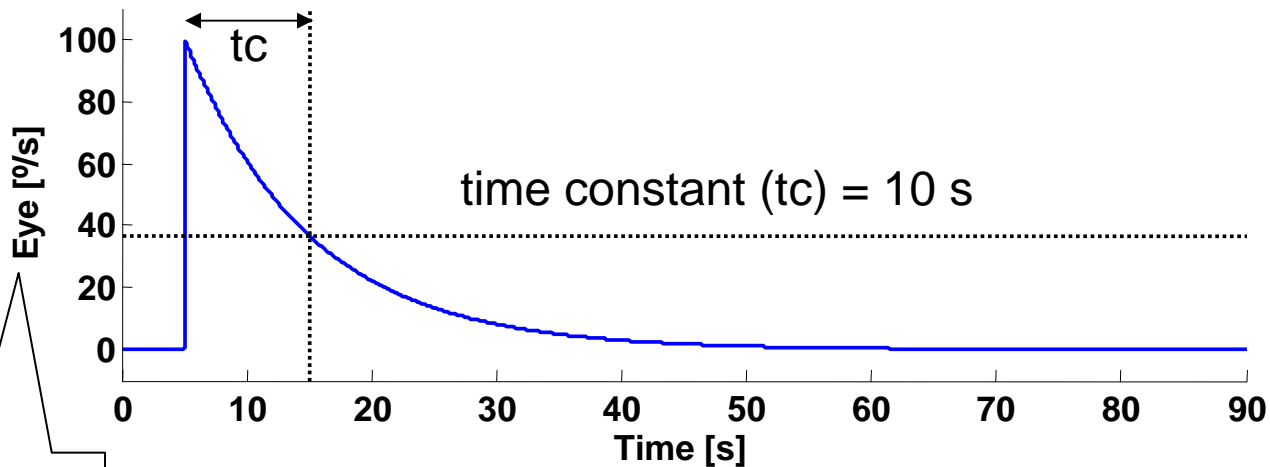
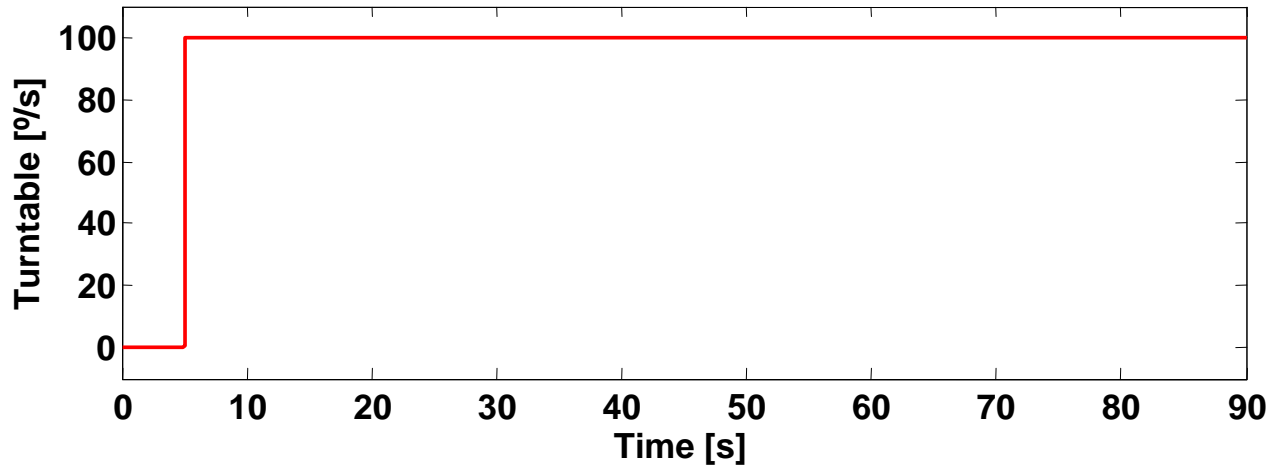

slow-phase  
eye velocity

# Responses to velocity step

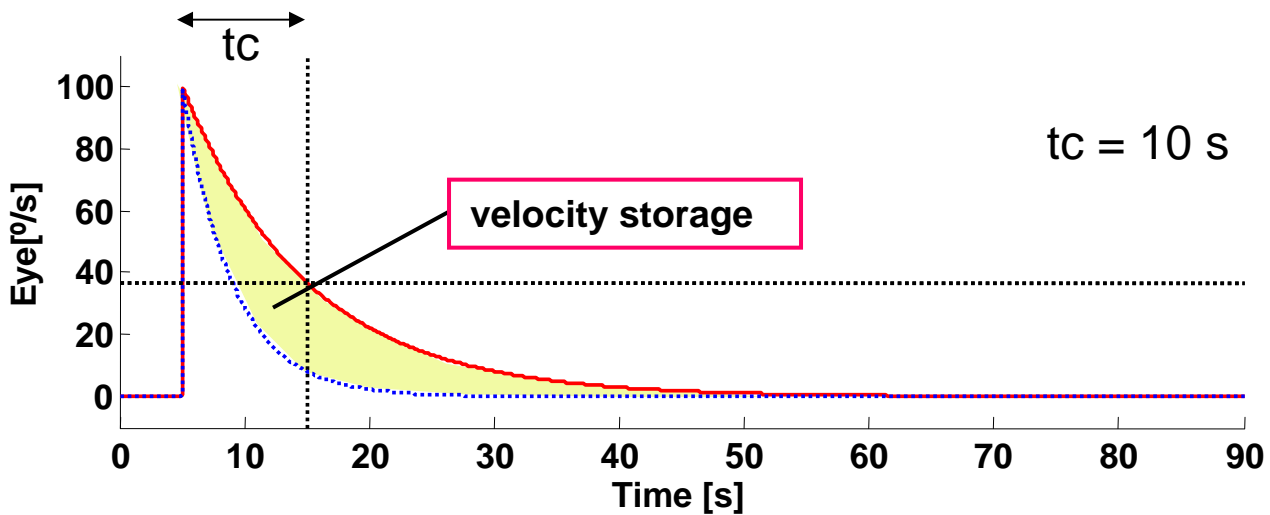
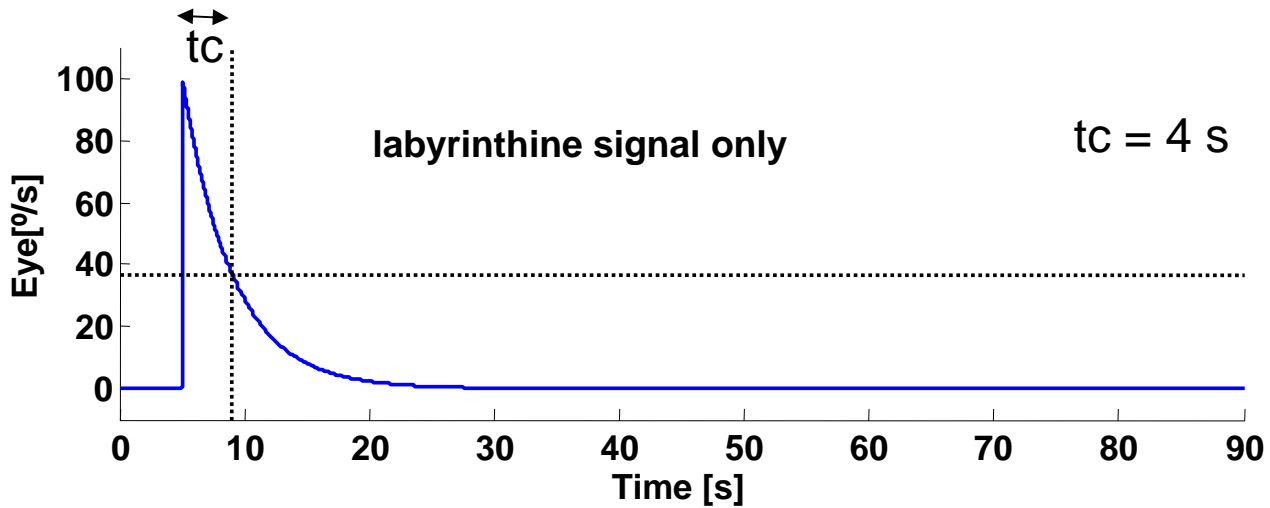

# Models of velocity storage

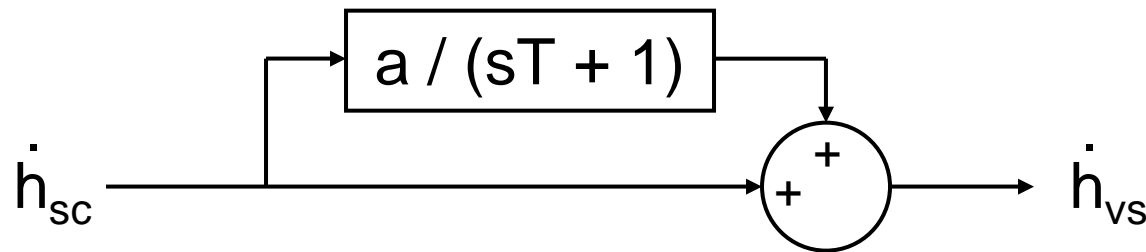

feedforward  
leaky integrator  
(Raphan, Cohen)

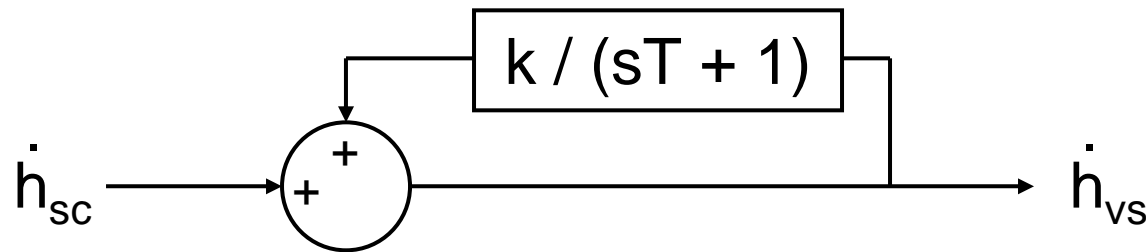

positive  
feedback  
(Robinson)

$\dot{h}_{sc}$ : signal from semicircular canals

$\dot{h}_{vs}$ : signal from velocity storage

# Bode plot

## Velocity storage

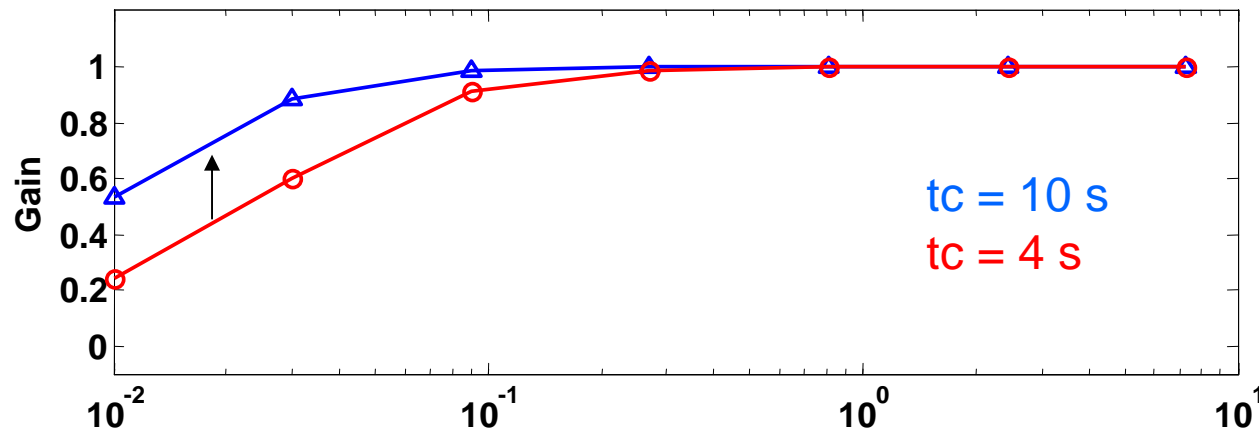

gain  $\uparrow$  at  
lower frequencies

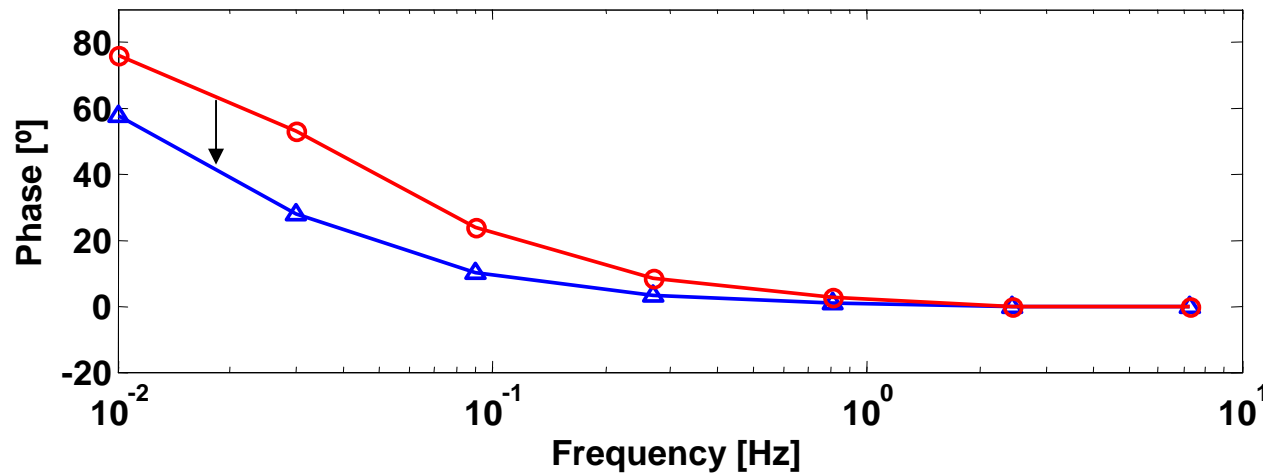

phase  $\downarrow$  at  
lower frequencies

**tc = 10 s**

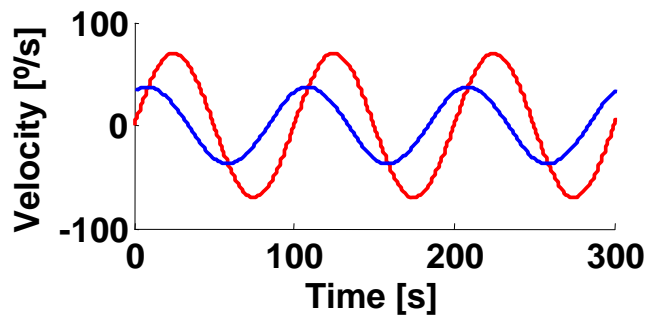
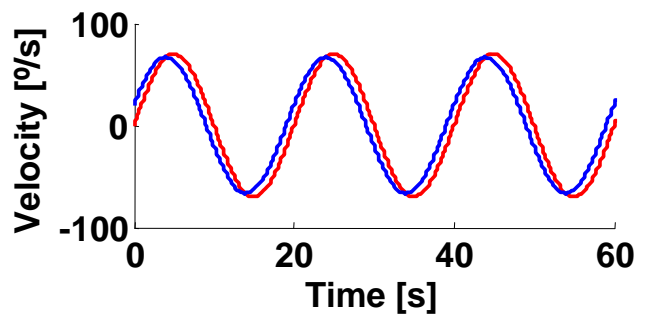
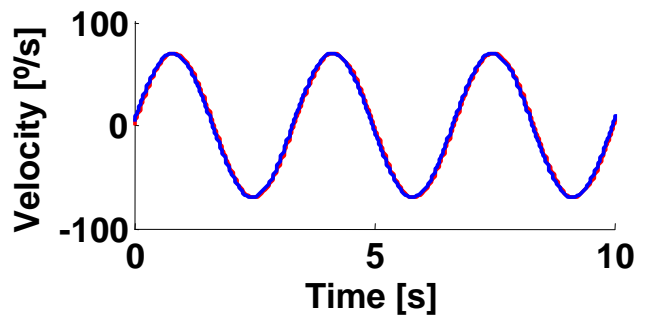

**tc = 4 s**

**0.3 Hz**

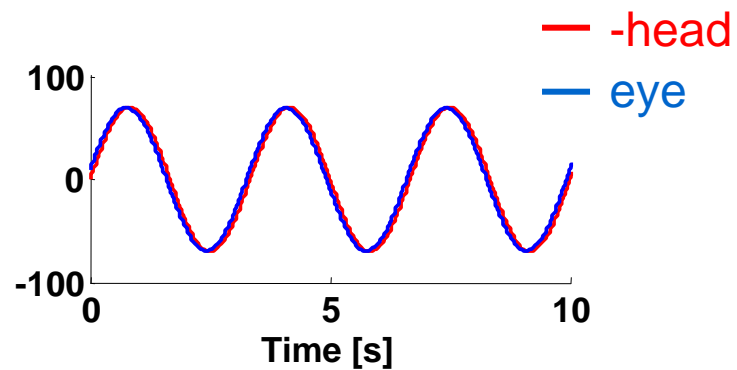

**0.05 Hz**

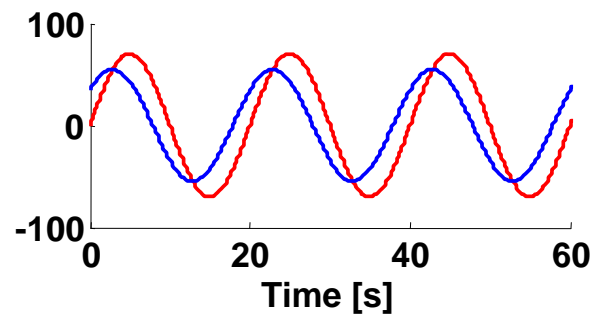

**0.01 Hz**

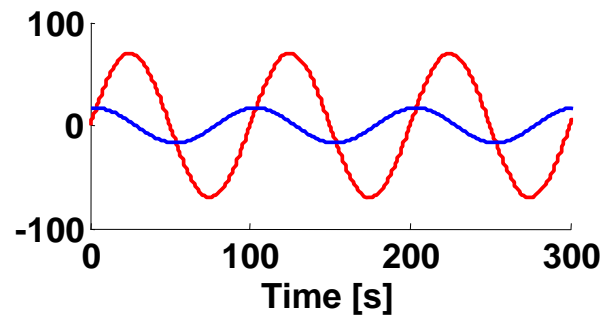

# Resting rate

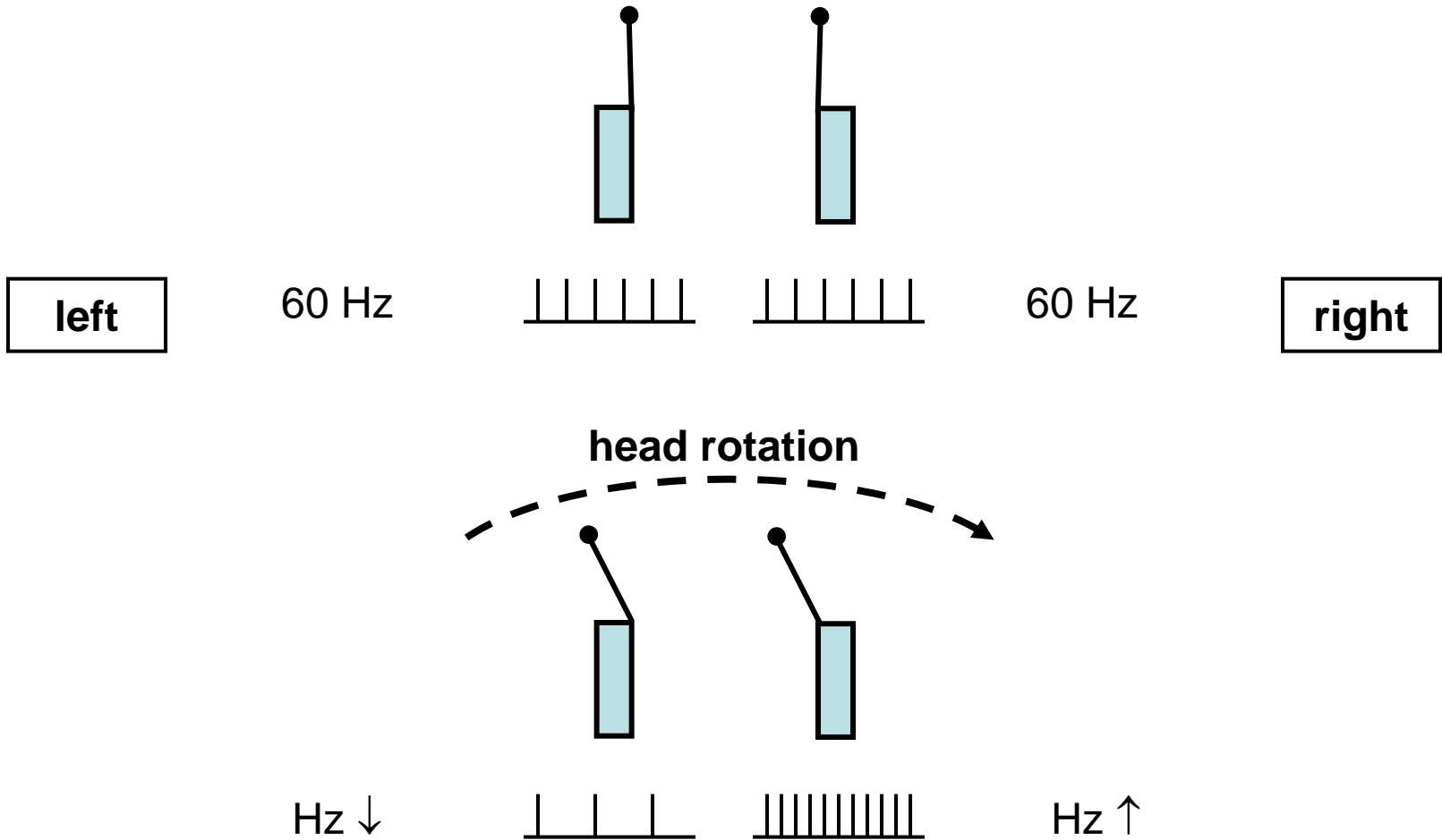

# Vestibular tone asymmetry

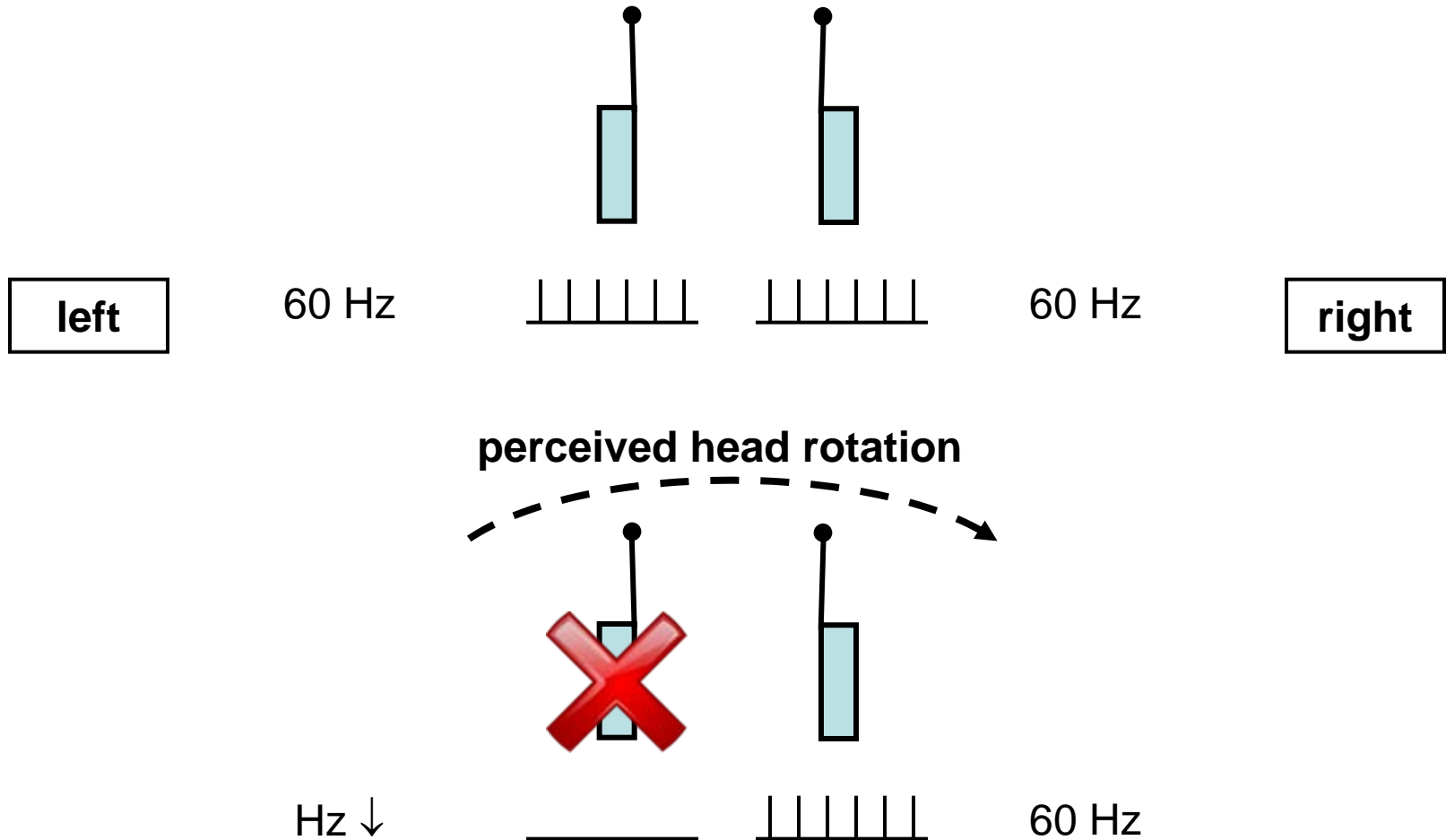

# Alexander's law

**Spontaneous  
nystagmus**

5 days after vestibular neuritis

# Mechanics of eye plant

- Elasticity

force  $\sim$  eccentricity

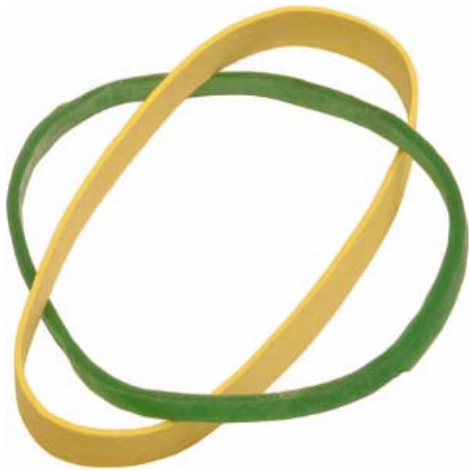

- Viscosity

force  $\sim$  velocity



# Firing rate ~ muscle length

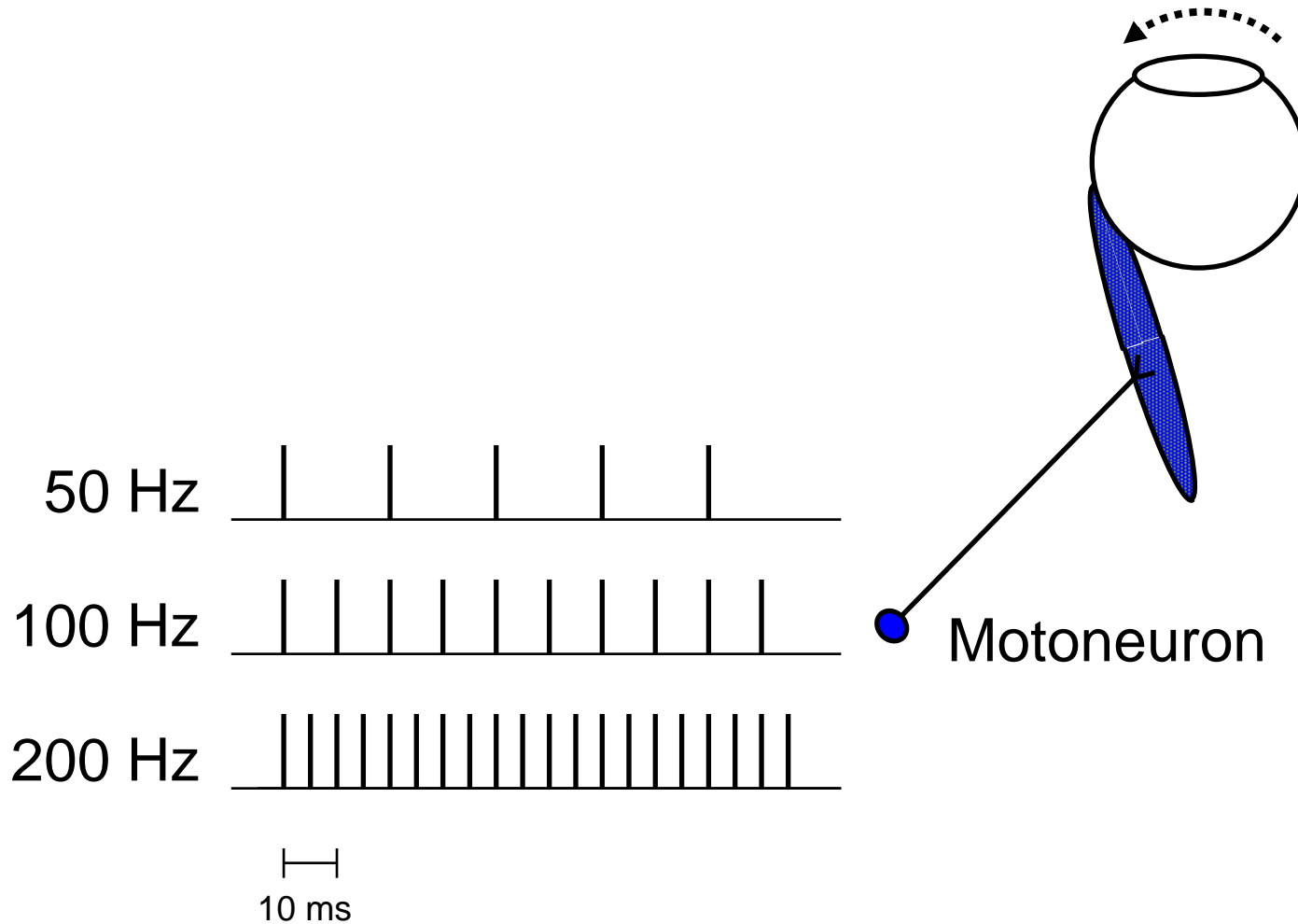

# Firing rate $\sim$ eye position

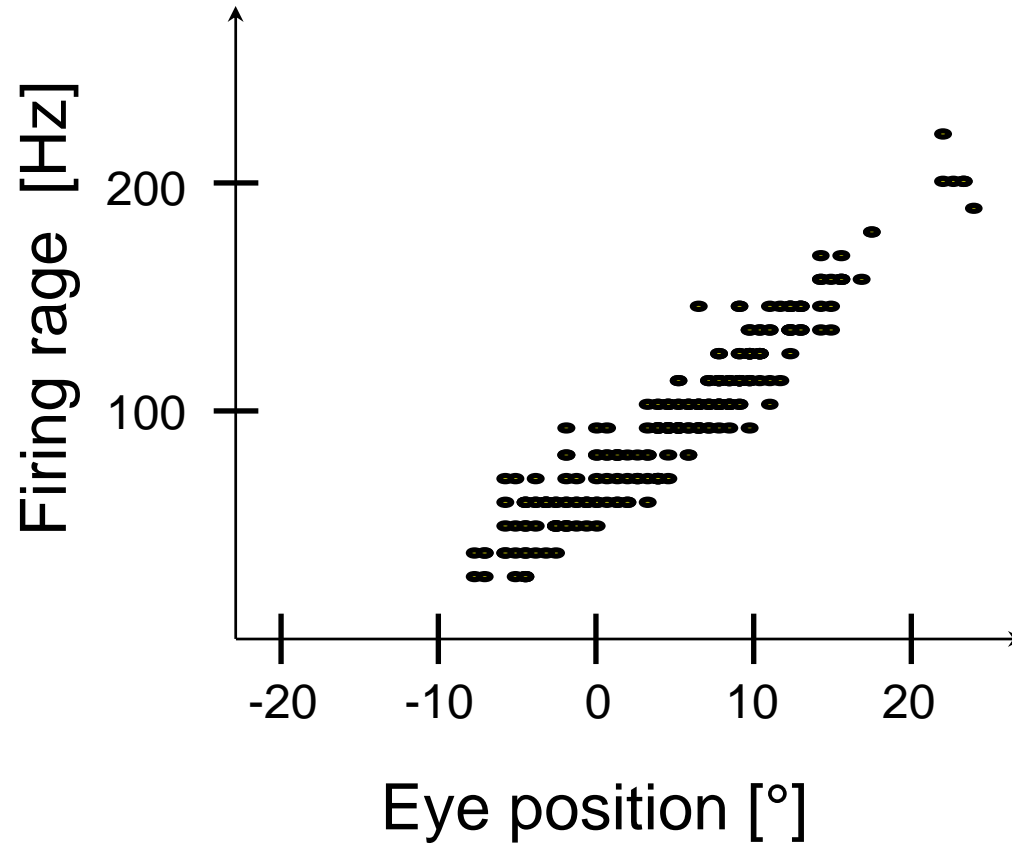

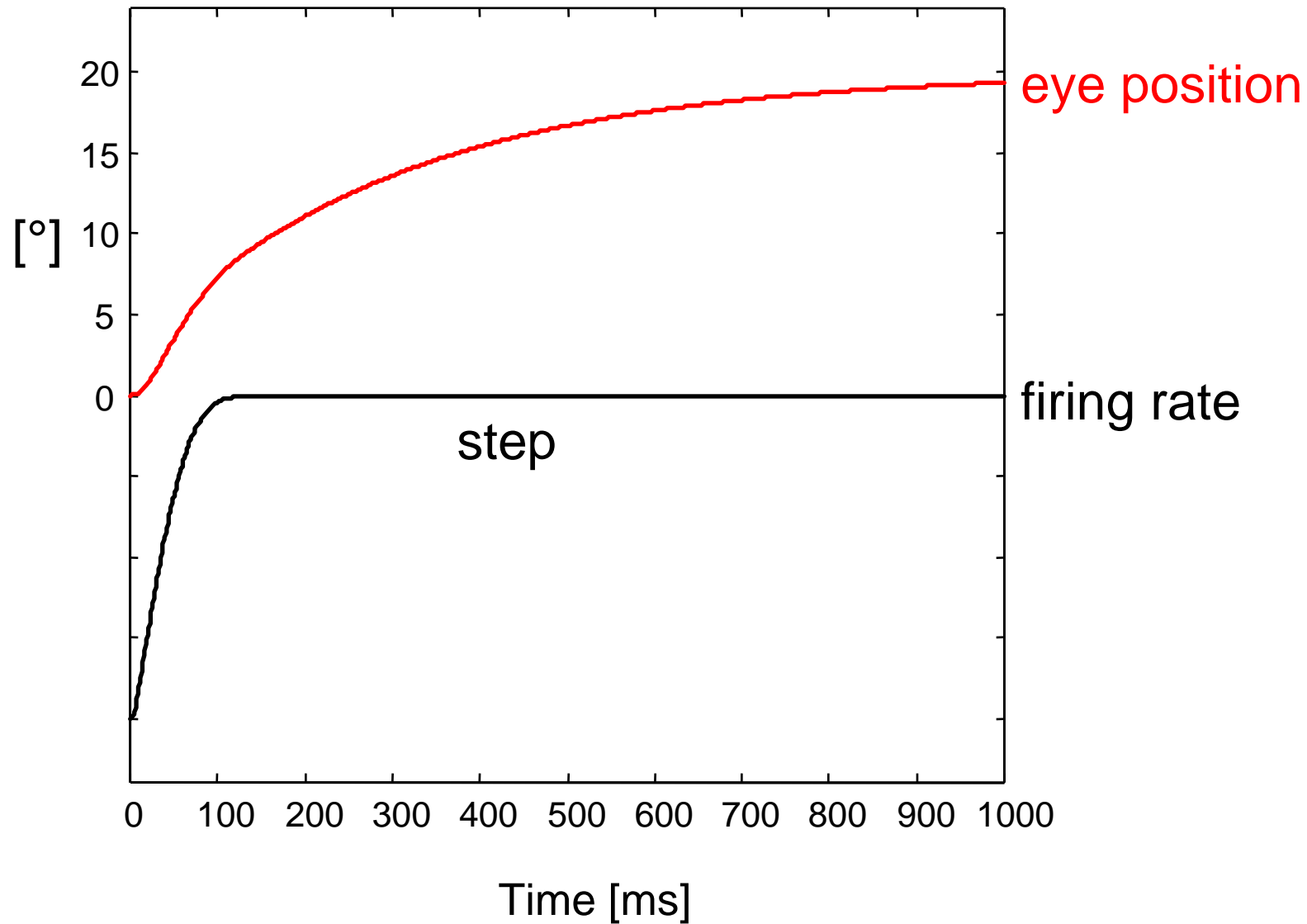

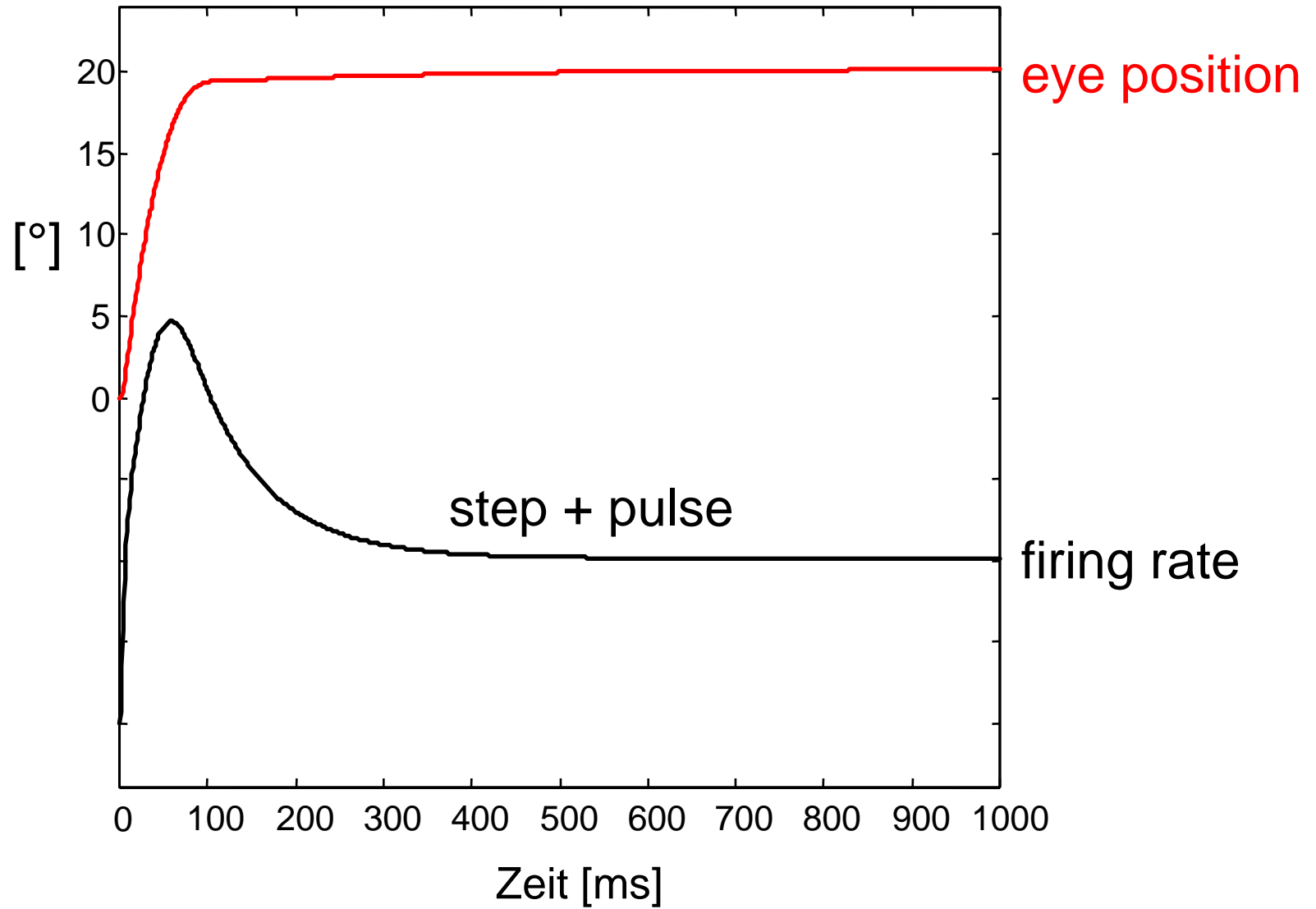

# Superior rectus motoneuron



vertical eye position



10°

100 ms

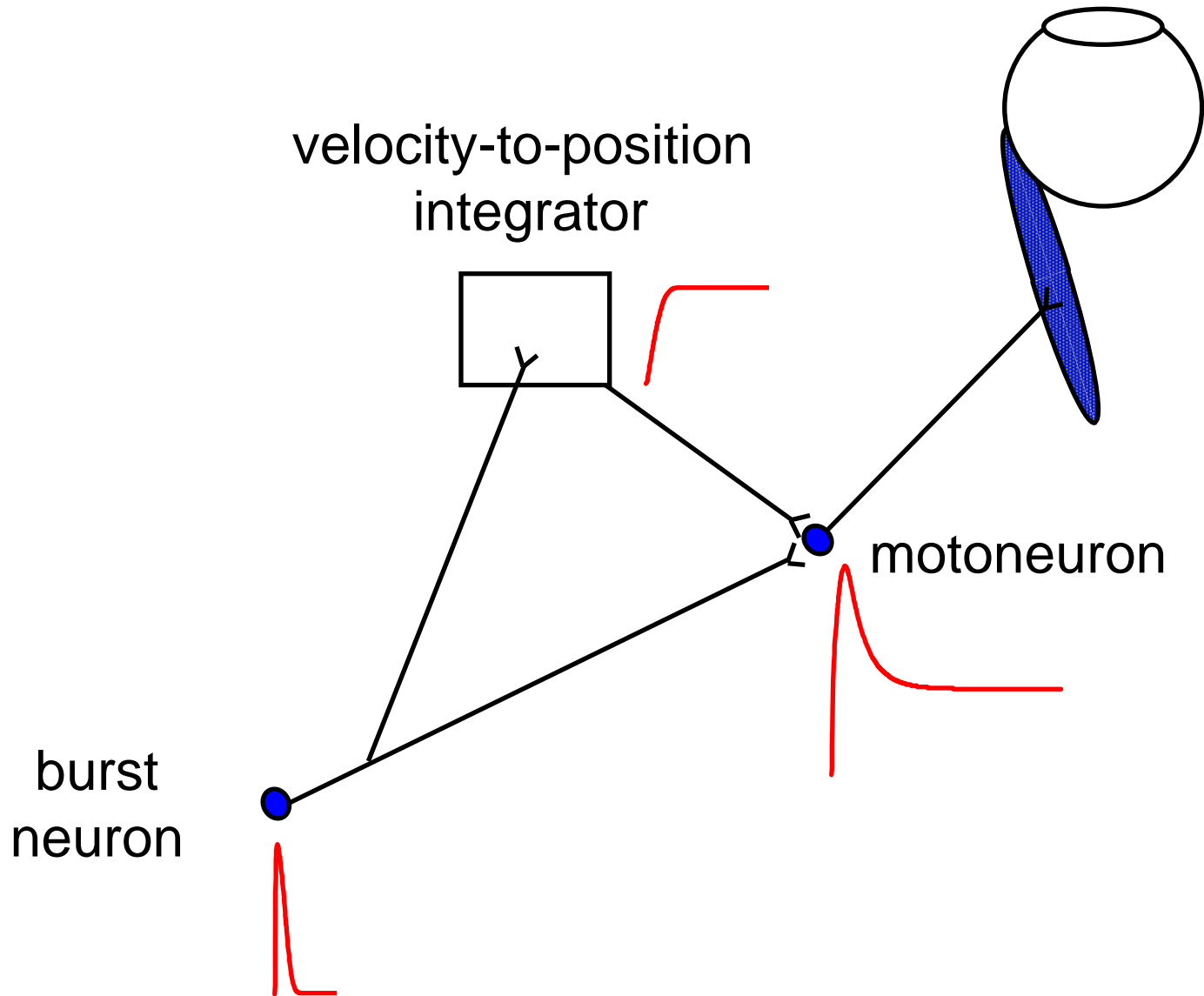

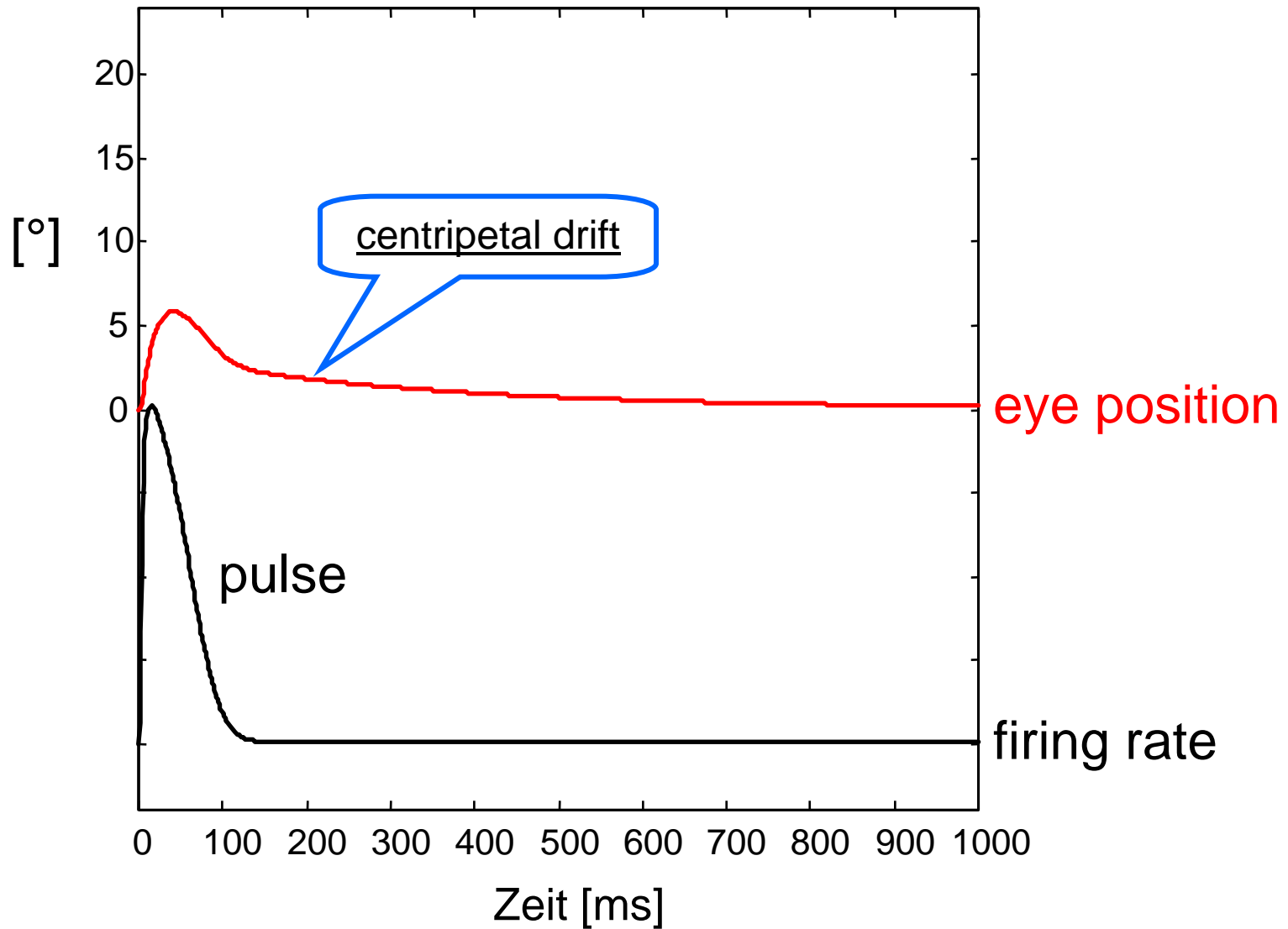

# position independent nystagmus (vestibular)



right gaze



straight ahead  
gaze

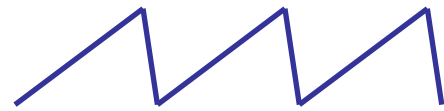

left gaze

position independent nystagmus (vestibular)  
+ gaze-evoked nystagmus (leaky integrator)

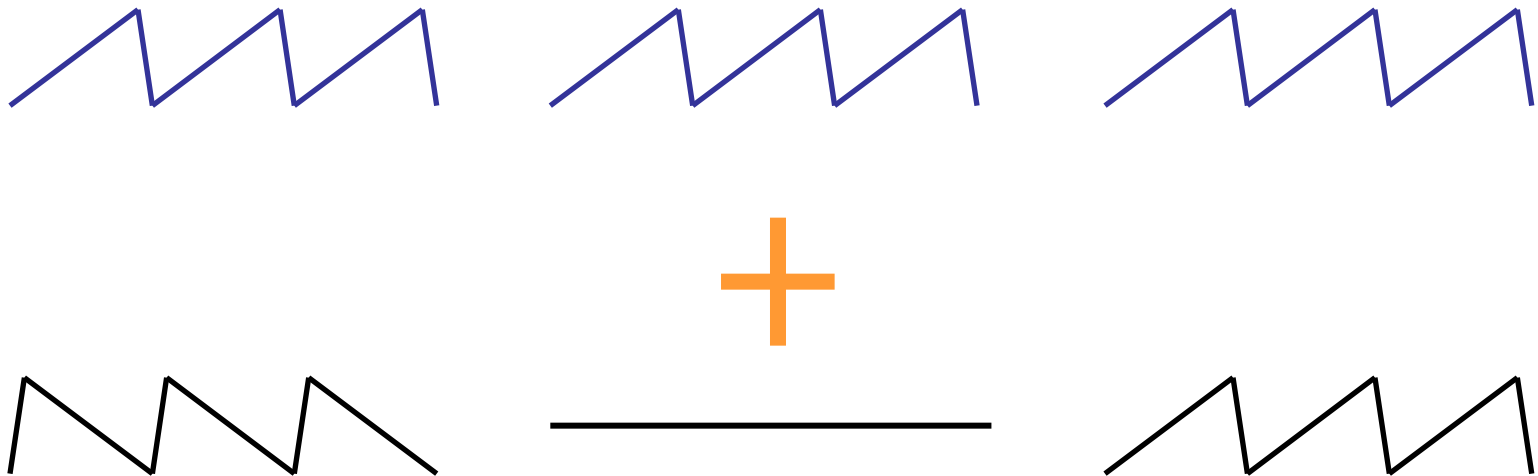

position independent nystagmus (vestibular)  
+ gaze-evoked nystagmus (leaky integrator)  
= spontaneous nystagmus according to  
Alexander's law

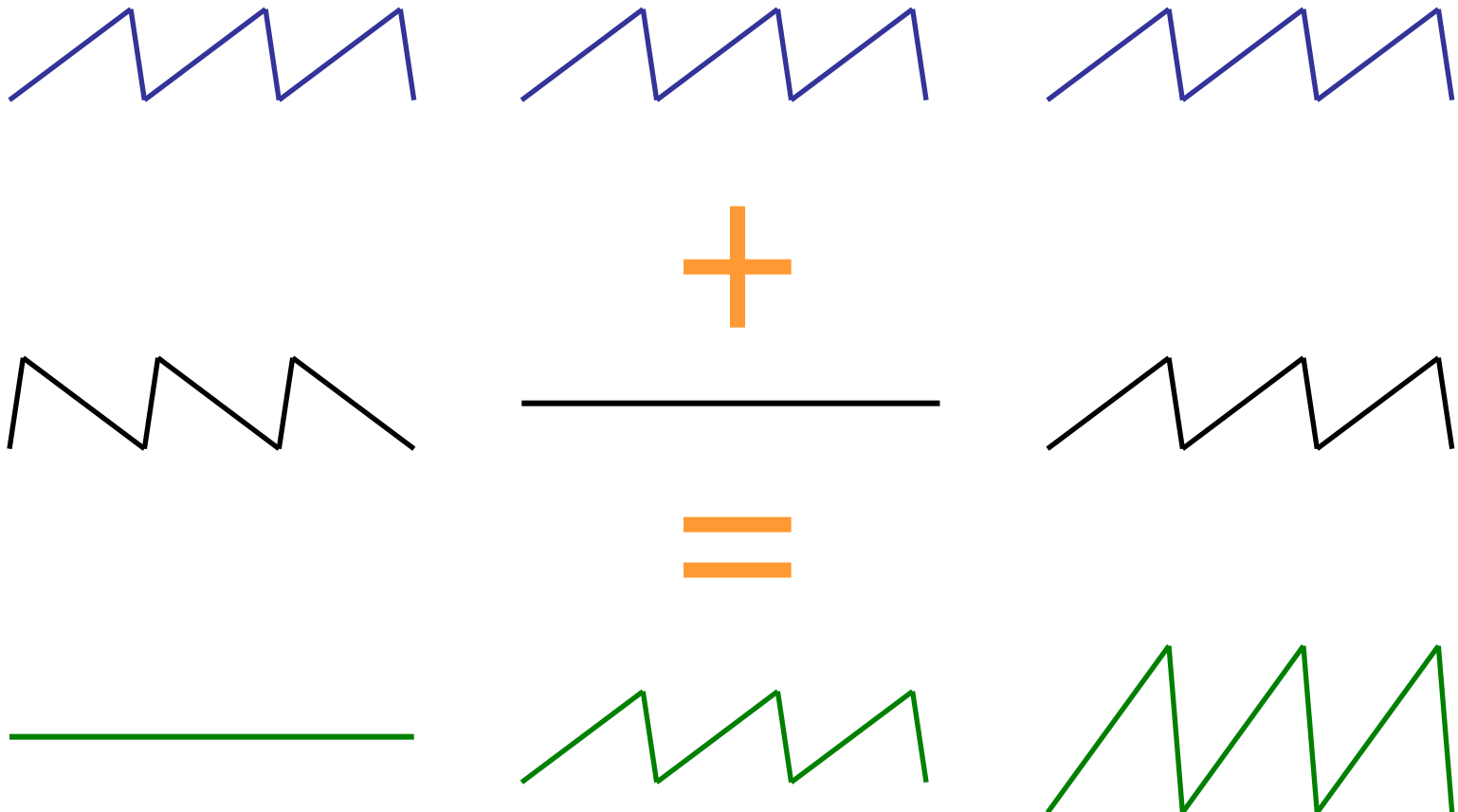

# Alexander's law in downbeat nystagmus



bias drift

gaze-evoked  
drift

downbeat  
nystagmus

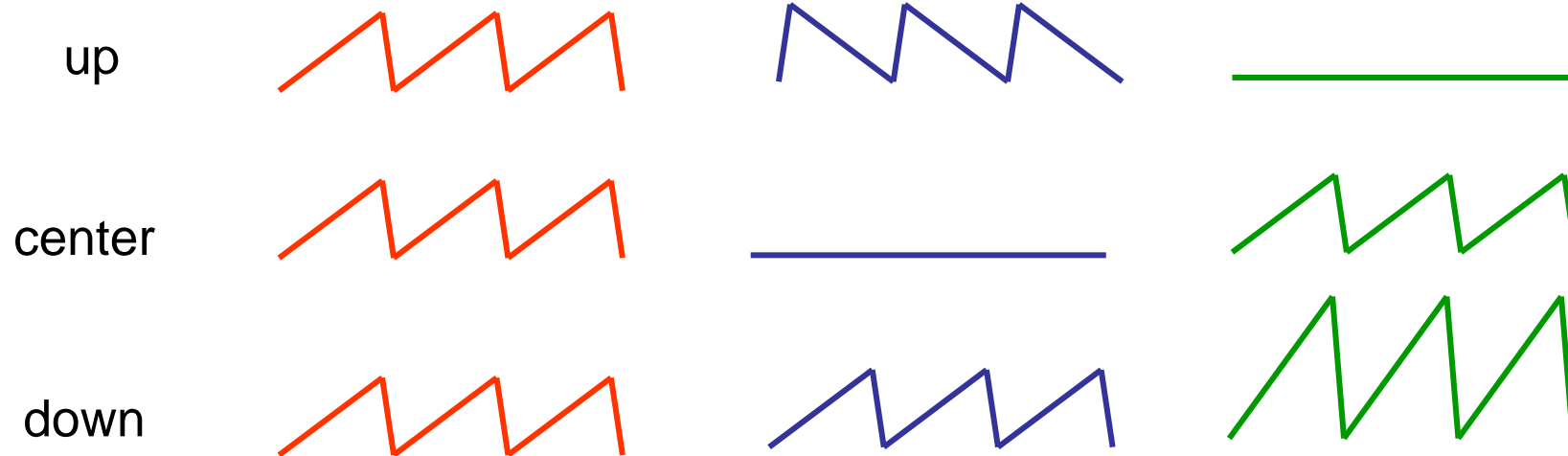

+

=

# Downbeat nystagmus

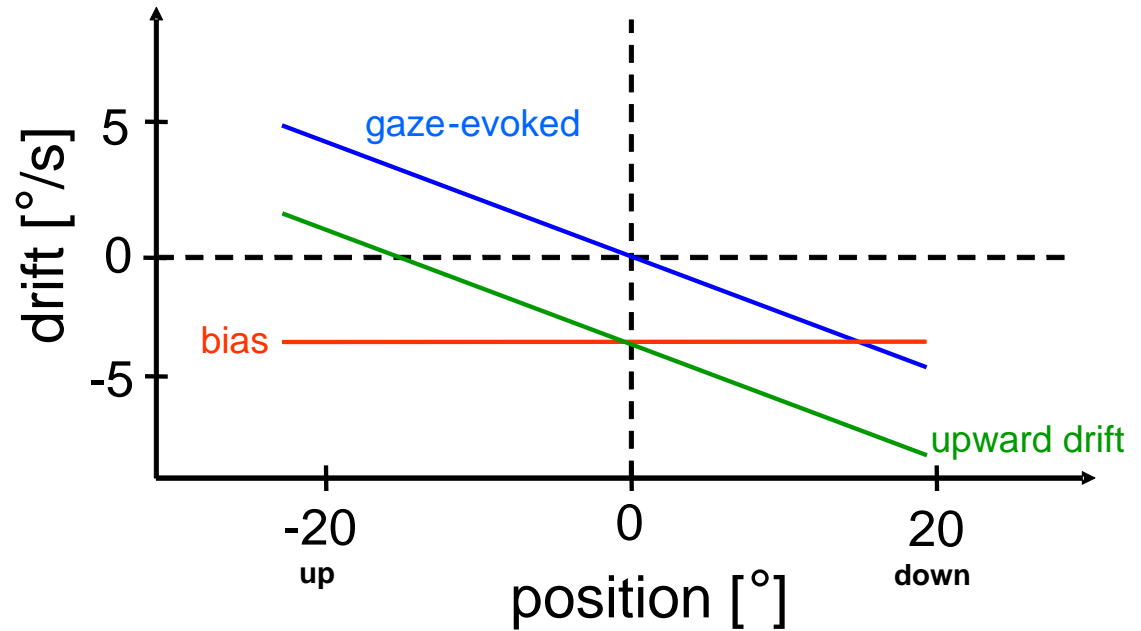
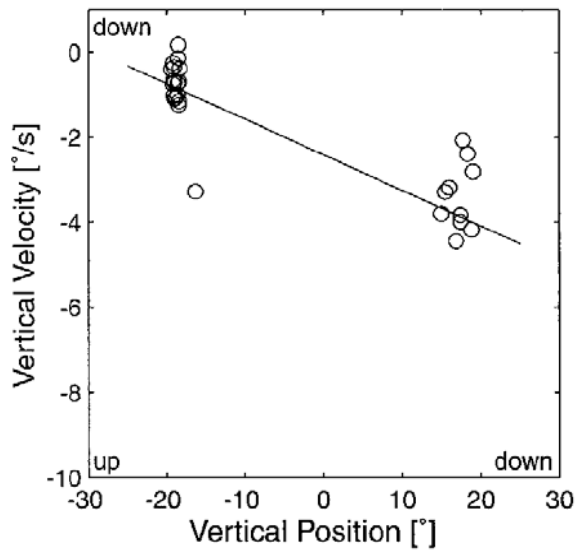

# Push-pull semicircular canals

Top View

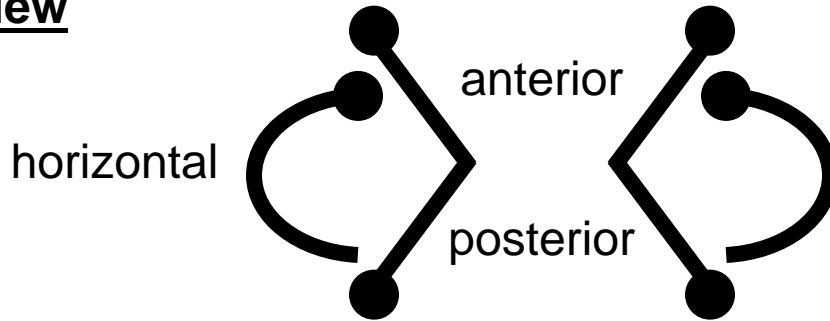

● ampulla

**Right Horizontal –  
Left Horizontal  
(RHLH)**

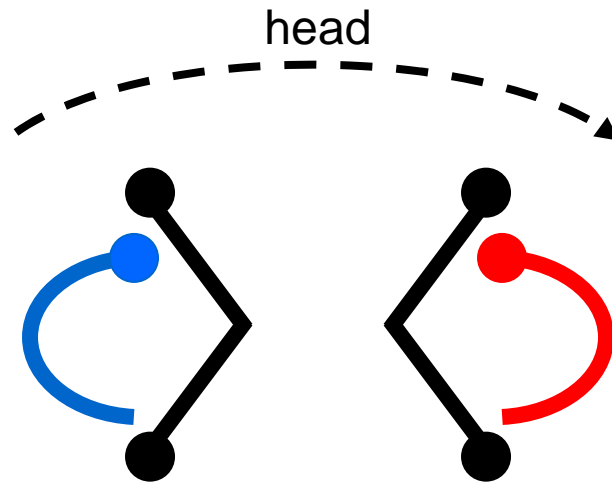

— excitation  
— inhibition

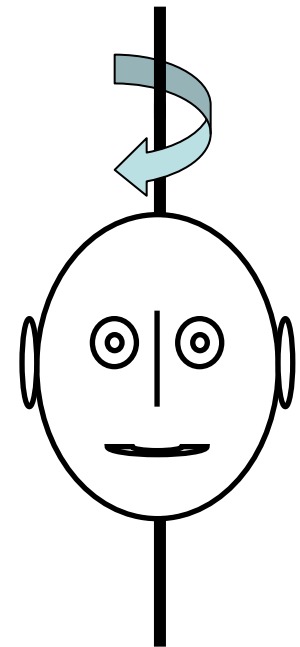

# Push-pull semicircular canals

Right Anterior –  
Left Posterior  
(RALP)

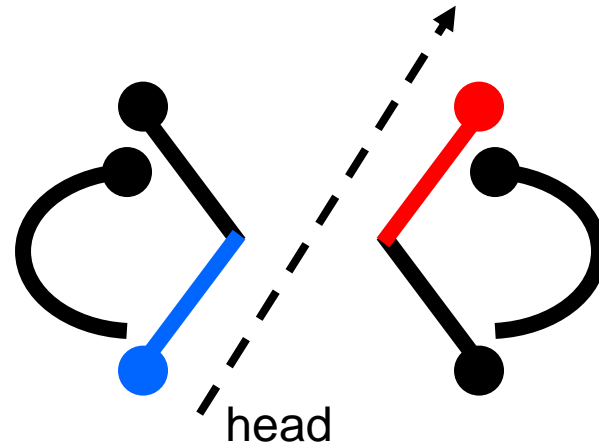

Right Anterior –  
Left Posterior  
(RPLA)

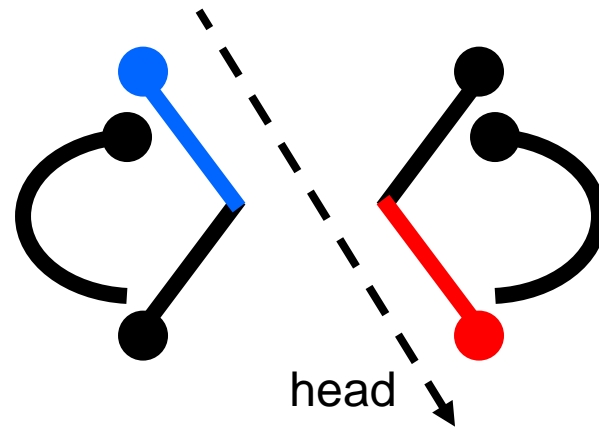

— excitation  
— inhibition

● ampulla

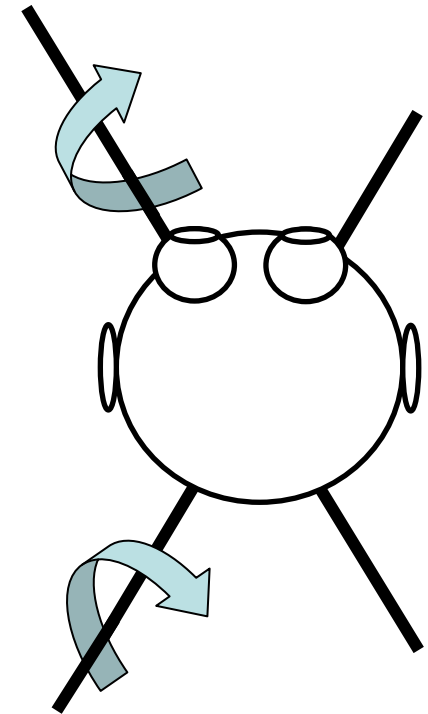

# Ewald's 2<sup>nd</sup> law

Excitation drives the VOR better than inhibition (1892).

## linear pathway

- excitation  $\approx$  -inhibition
- not cutoff (always  $> 0$  Hz)

## nonlinear pathway

- excitation only
- sensitive to high accelerations

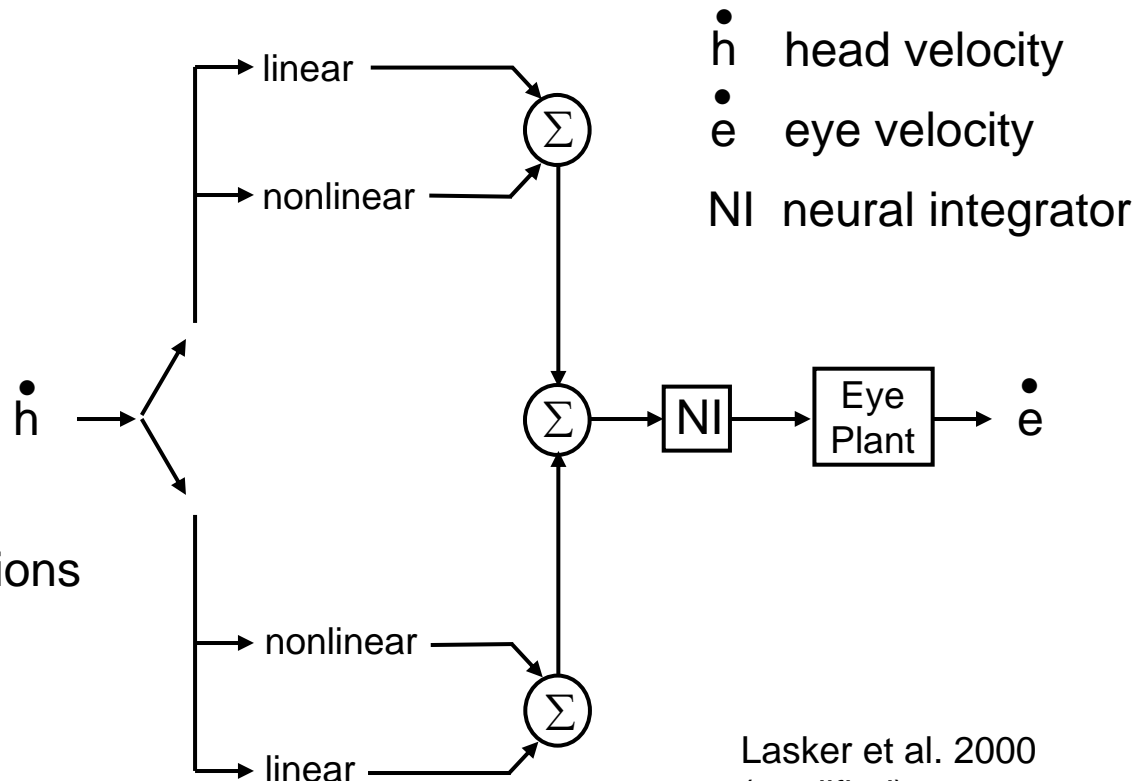

Lasker et al. 2000  
(modified)

# Normal head-impuls test\*

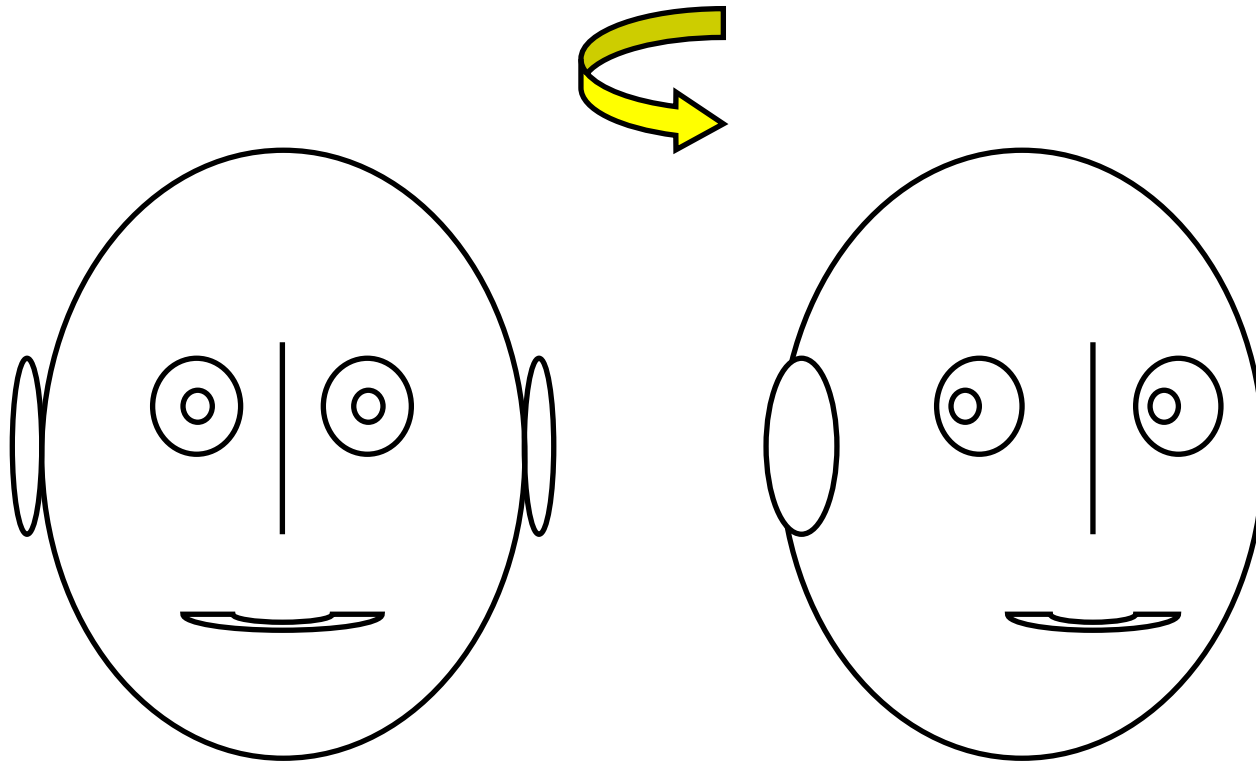

\*Halmagyi G.M., Curthoys I.S (1988)  
Archives of Neurology

# Horizontal head impulses

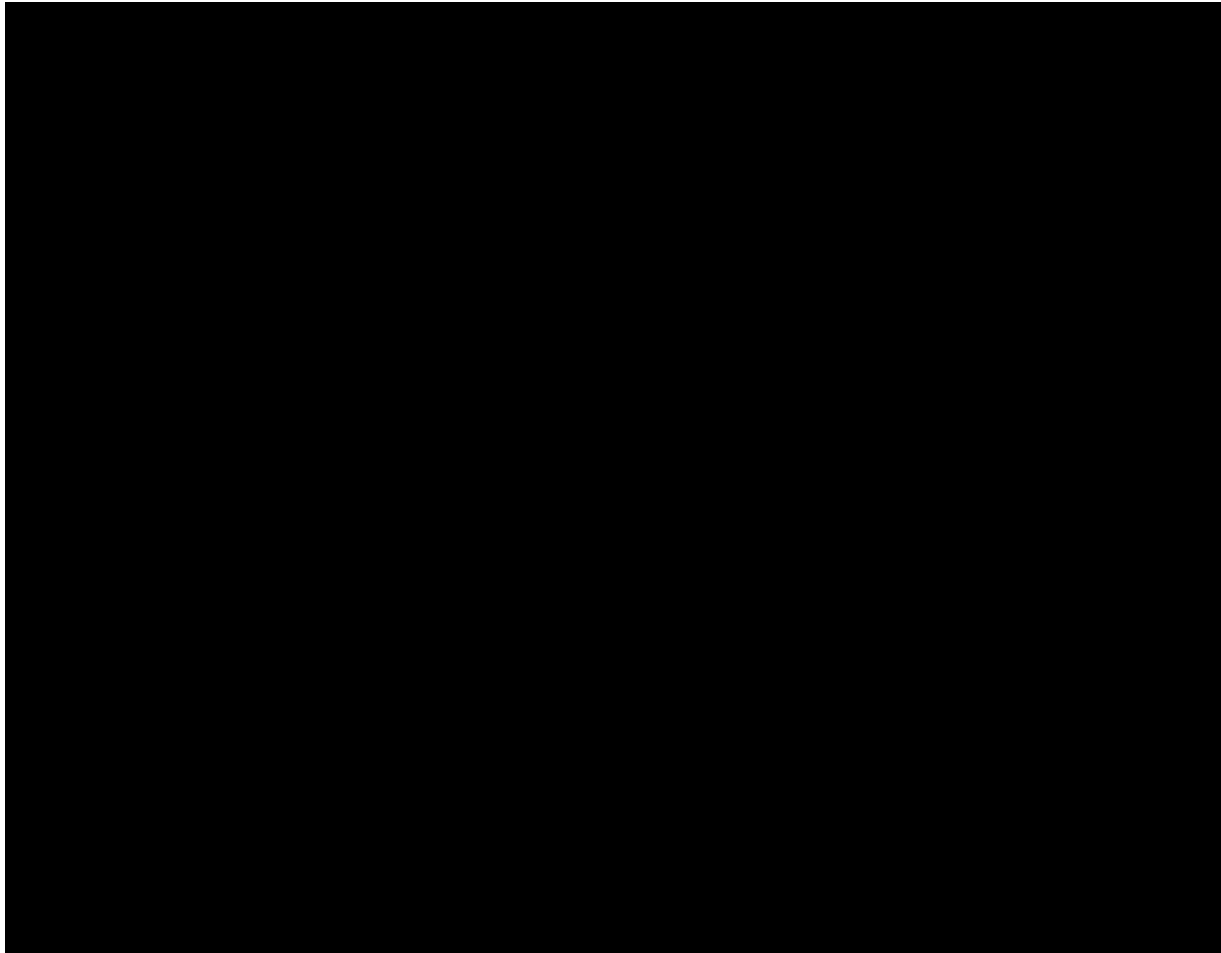

# Search-coil head impulse test

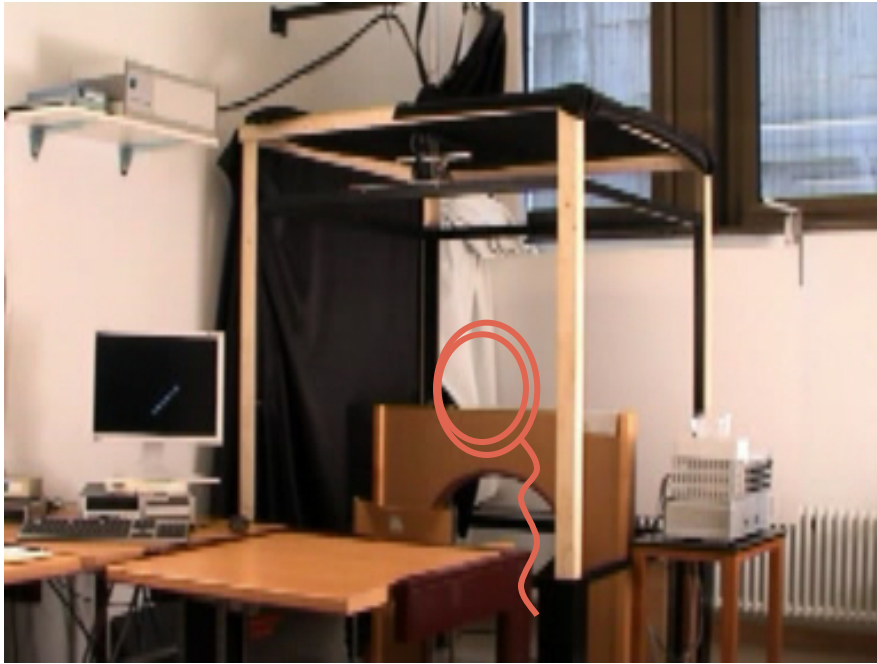

3D magnetic field



David A. Robinson:  
„dual search coil  
technique“



modified silicon anulus  
by Collewijn et al.

Normal  
response

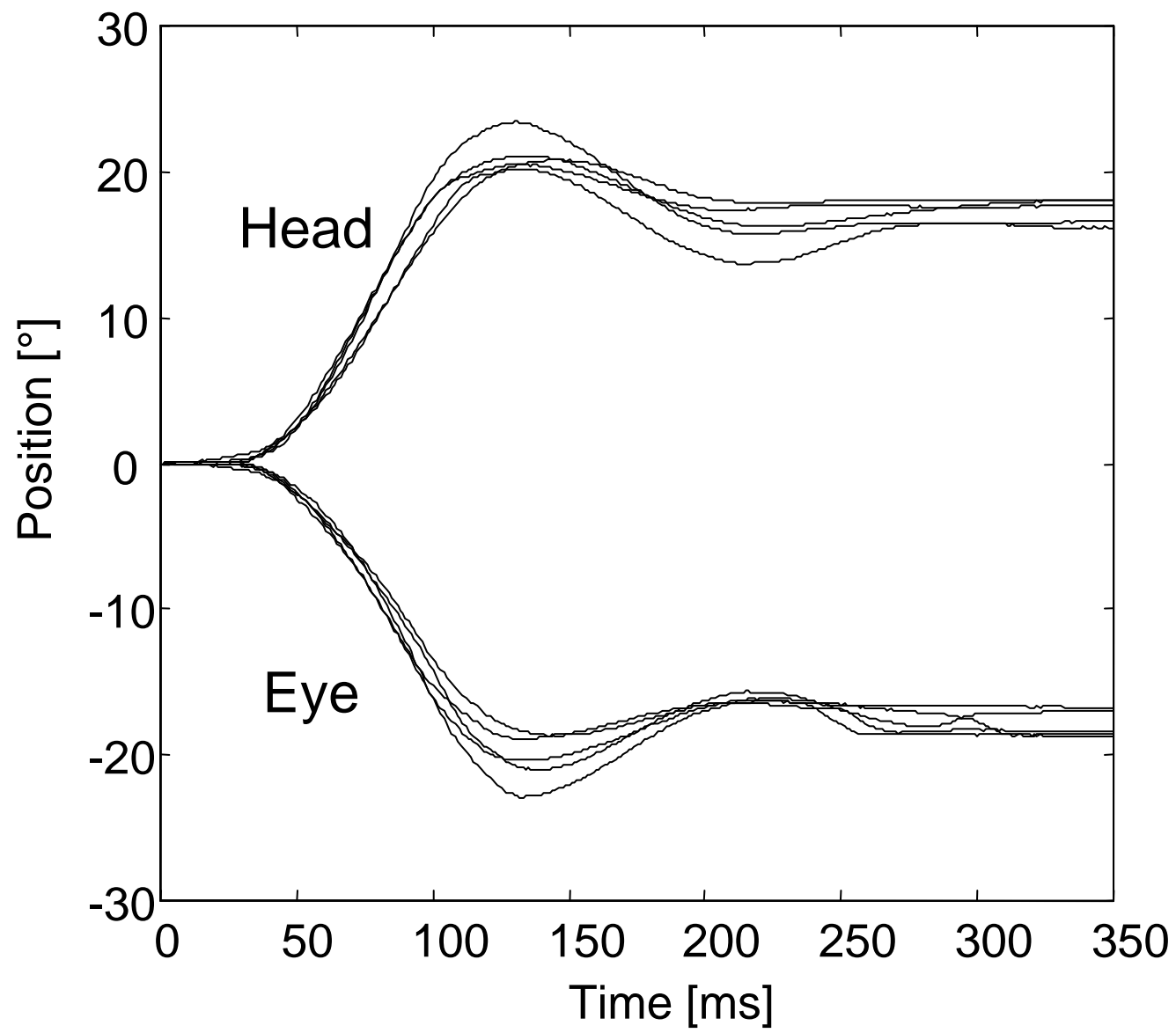

# Head not moving

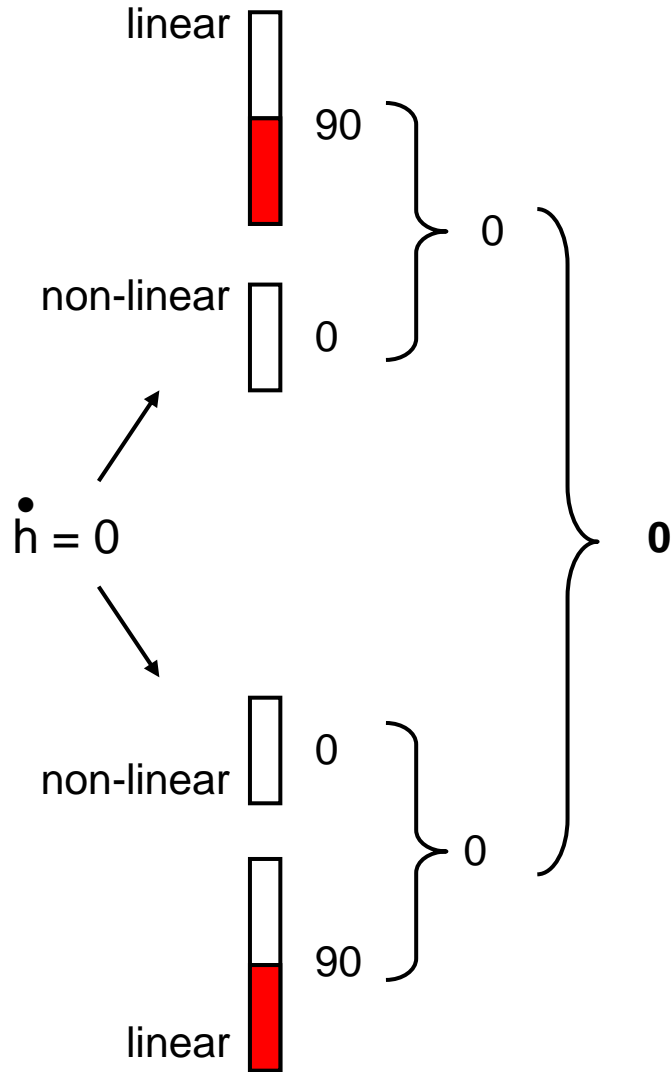

# Head impulse to the right

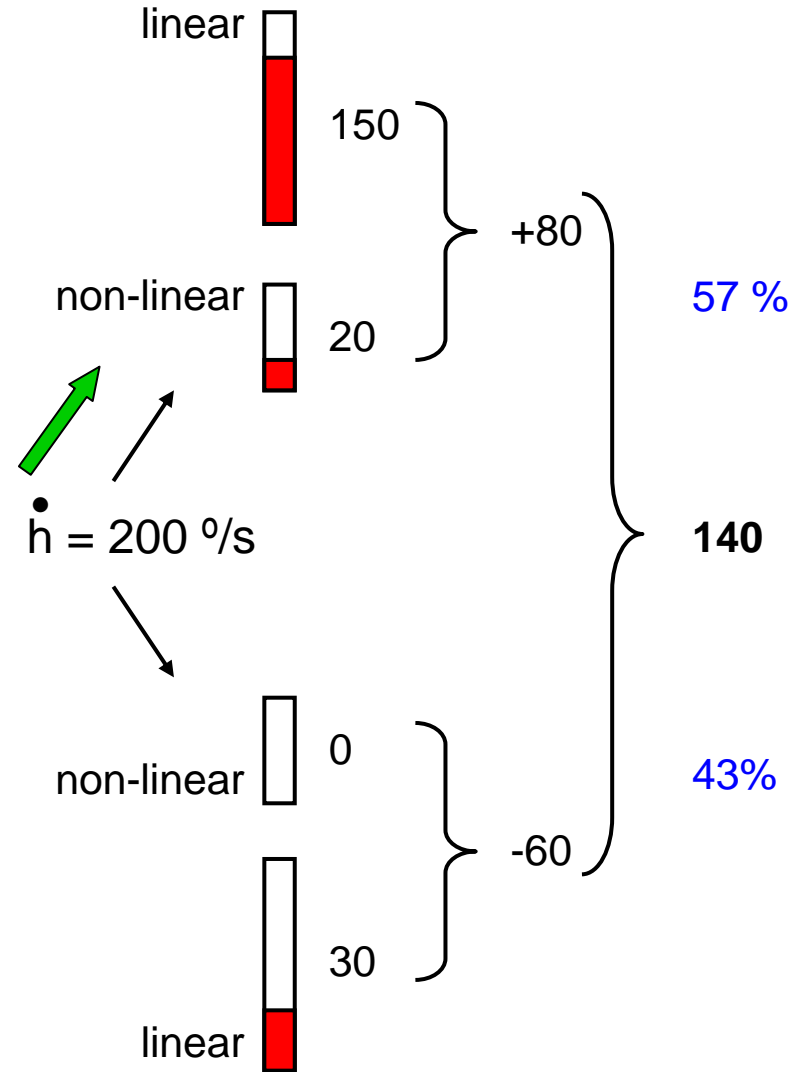

# Head impulse to the right

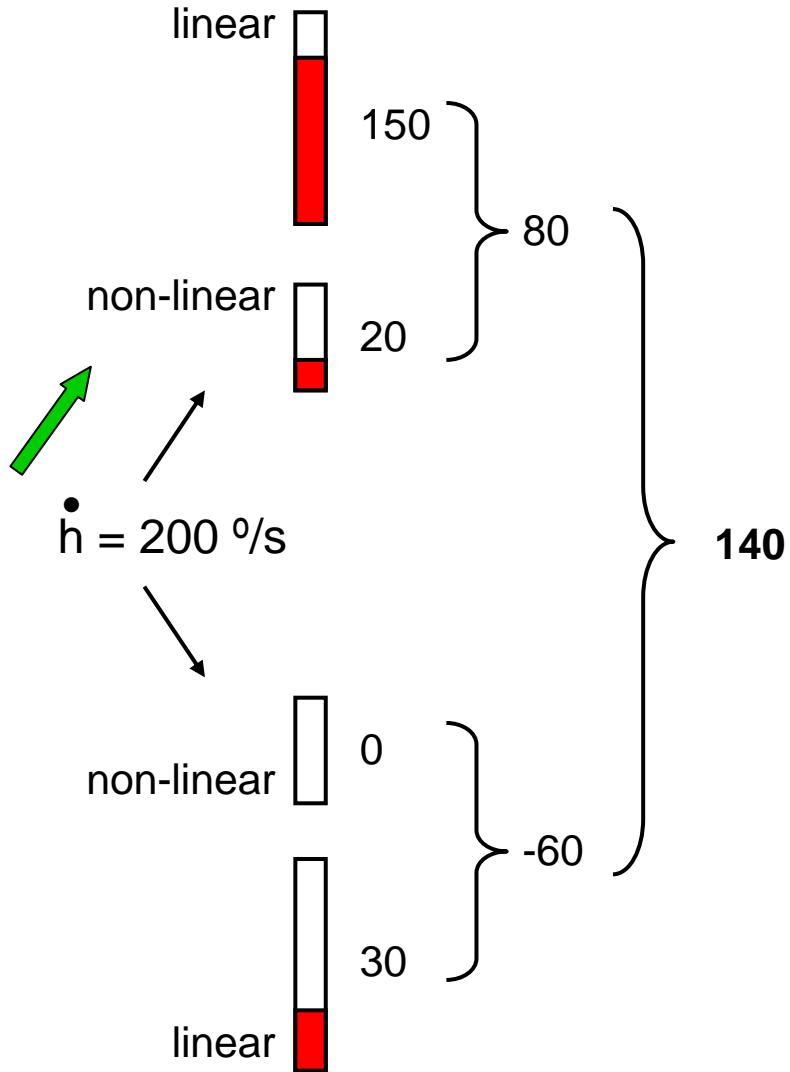

# Head impulse to the right

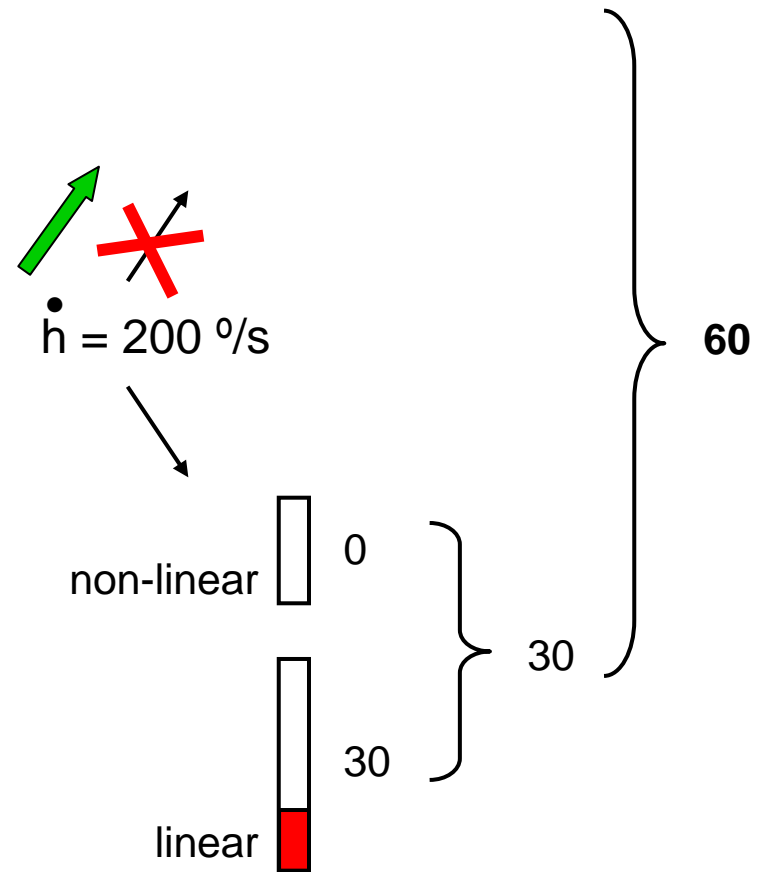

Vestibular deficit  
on the left

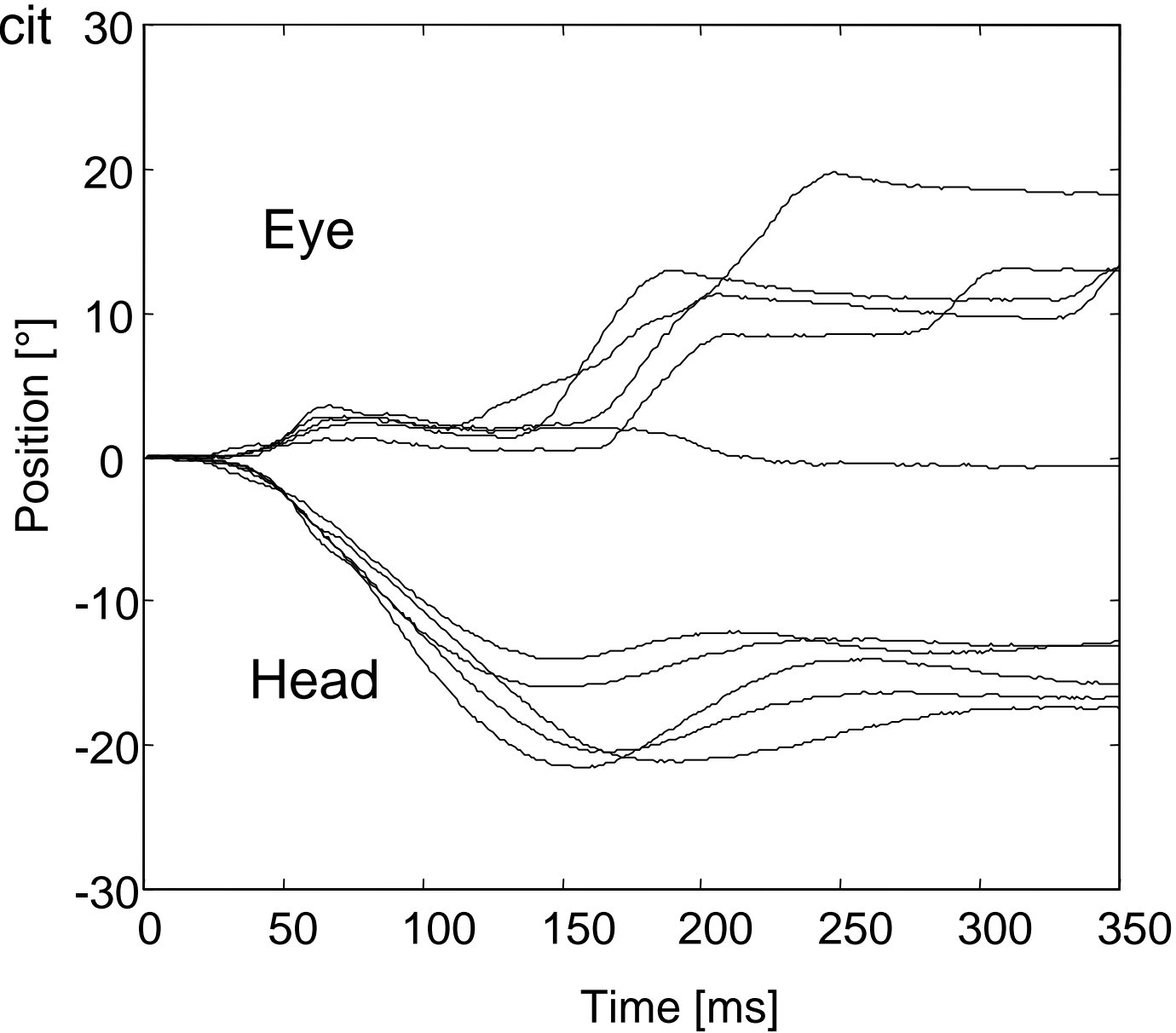

## Head impulse to the right

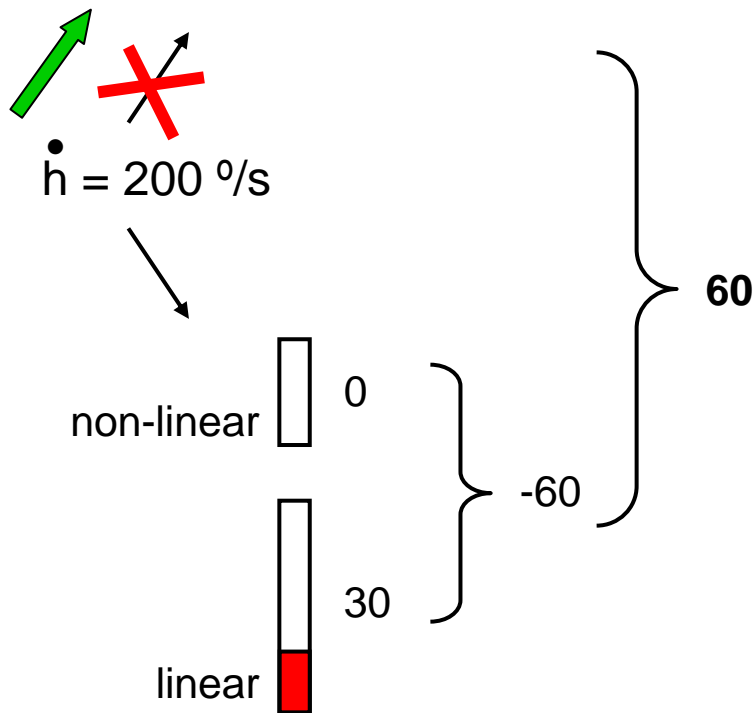

## Head impulse to the left

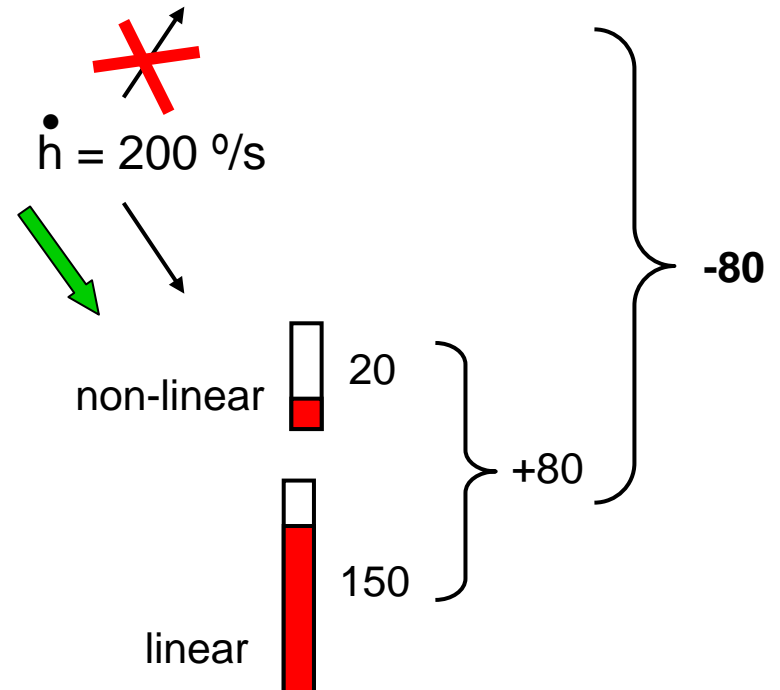

Gain reduction is greater during ipsilesional head acceleration.

## Head impulse to the right

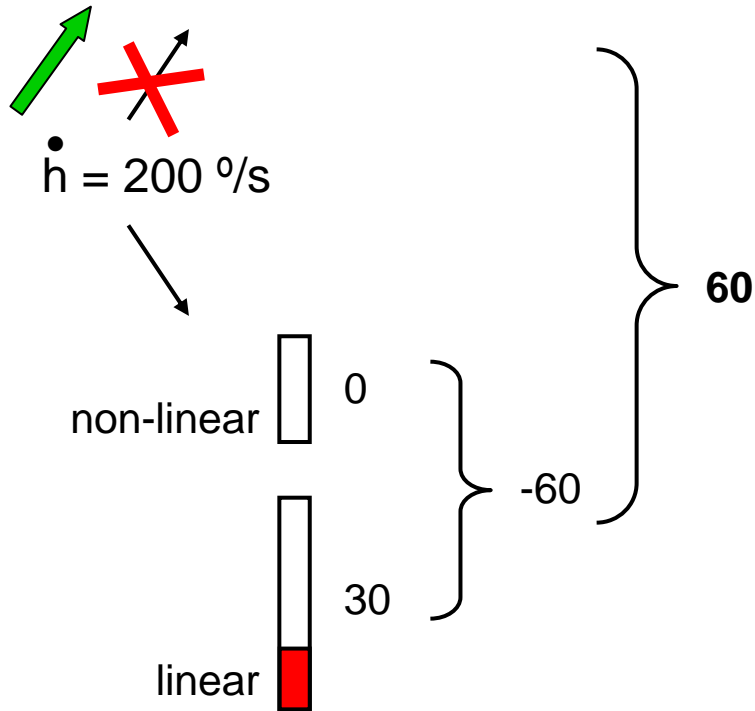

## Head impulse to the left

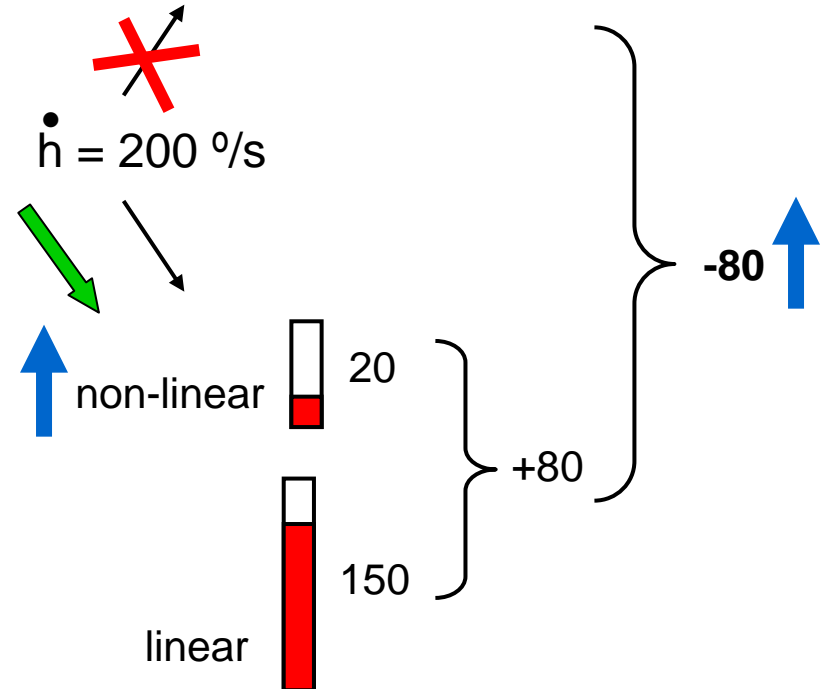

**central enhancement of  
contralesional nonlinear pathway**

contralesional gain  $\uparrow$   
gain asymmetry  $\uparrow$

# Horizontal head impulse testing

ipsilateral

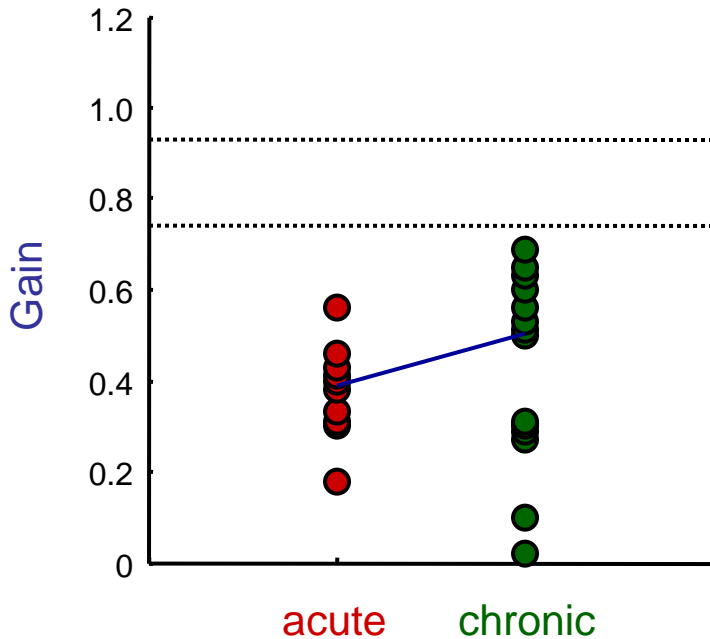

contralateral

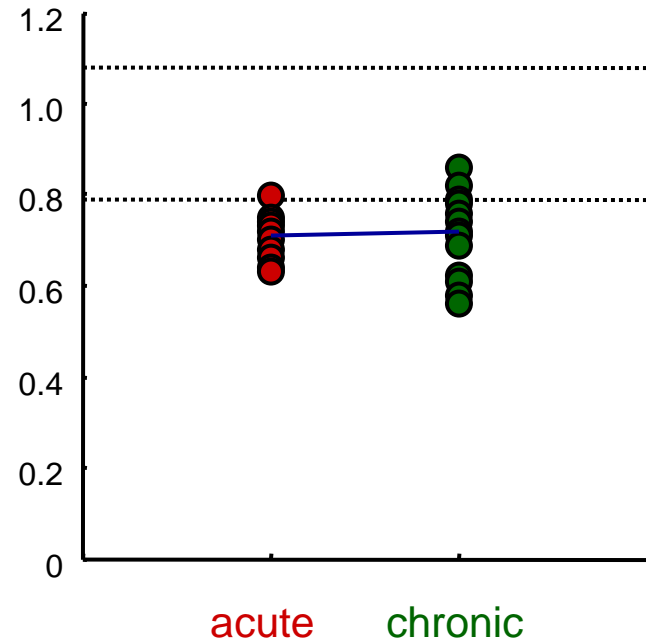

acute: < 3 days  
chronic: > 2 months

# Leftsided vestibular deficit

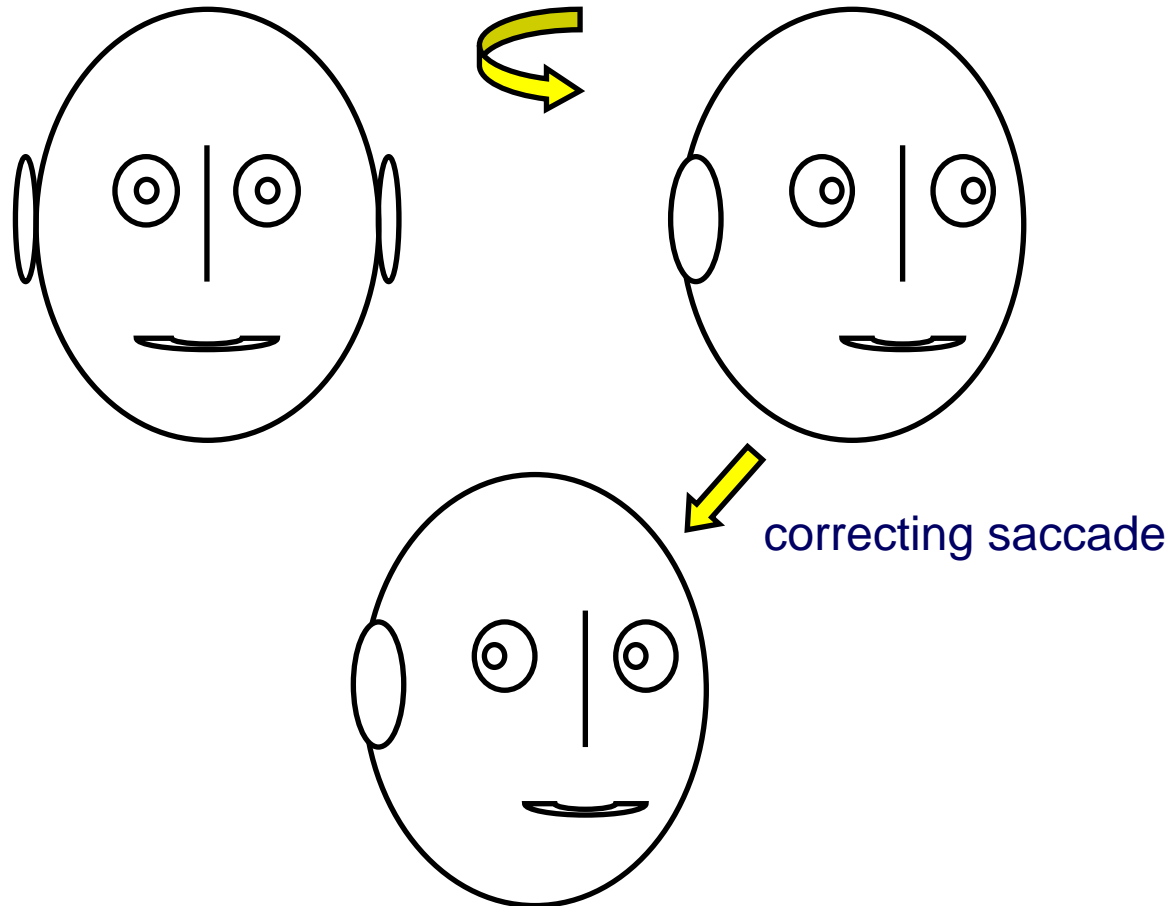

# Pathological head impulse test

**Unilateral  
vestibular  
neuritis**

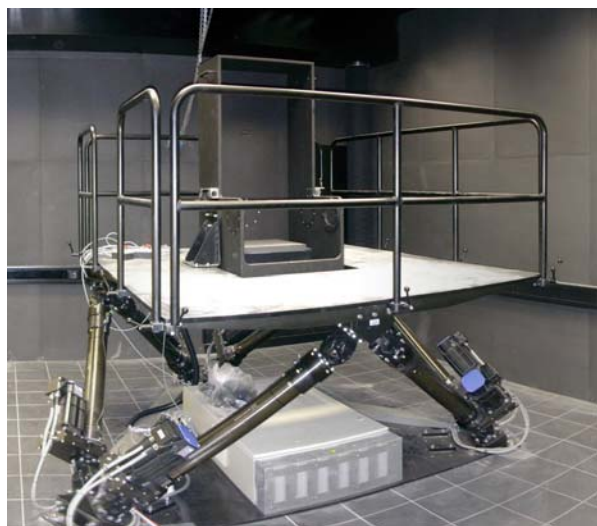
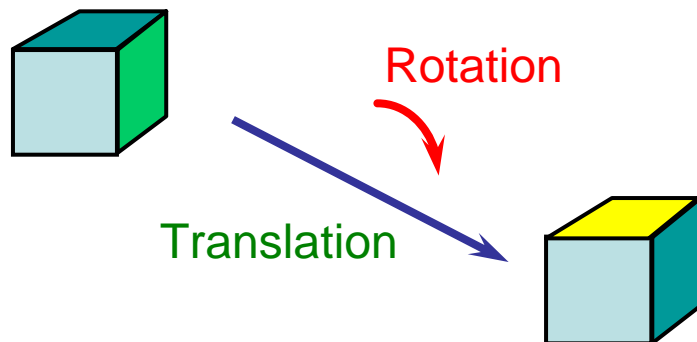

Motion simulator

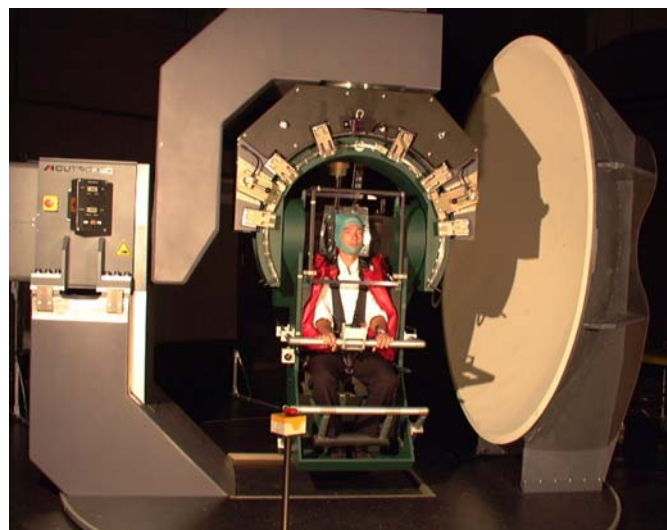

Turntable

# Linear vestibulo-ocular reflex

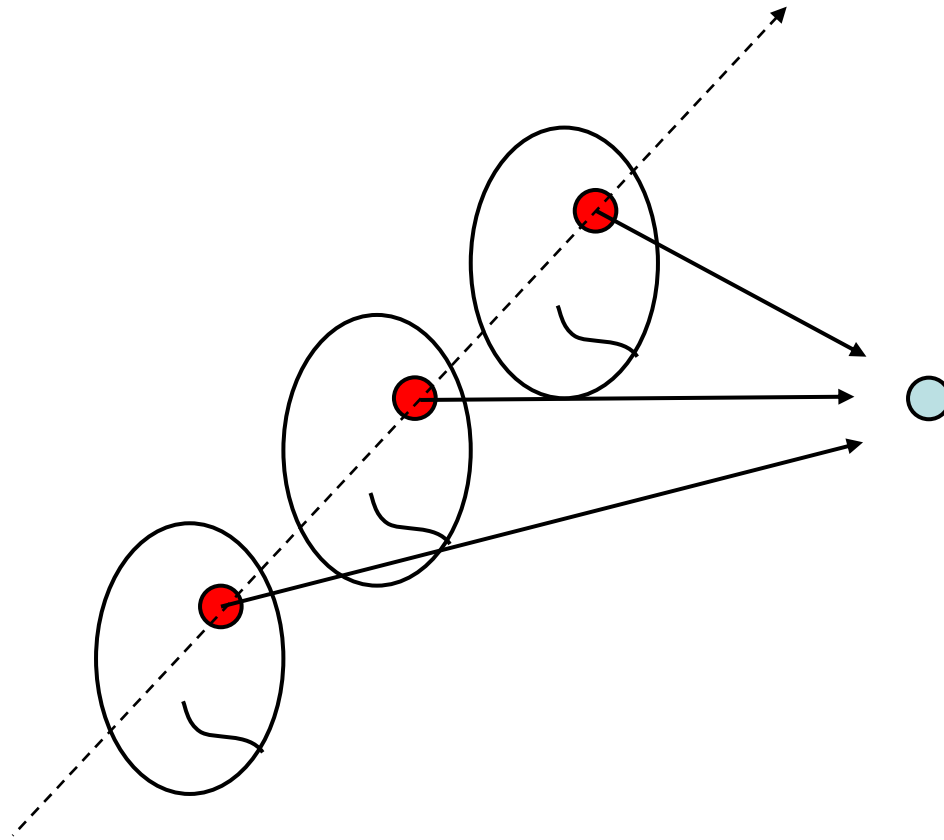



SWAY



HEAVE



SURGE

# Otolith organs

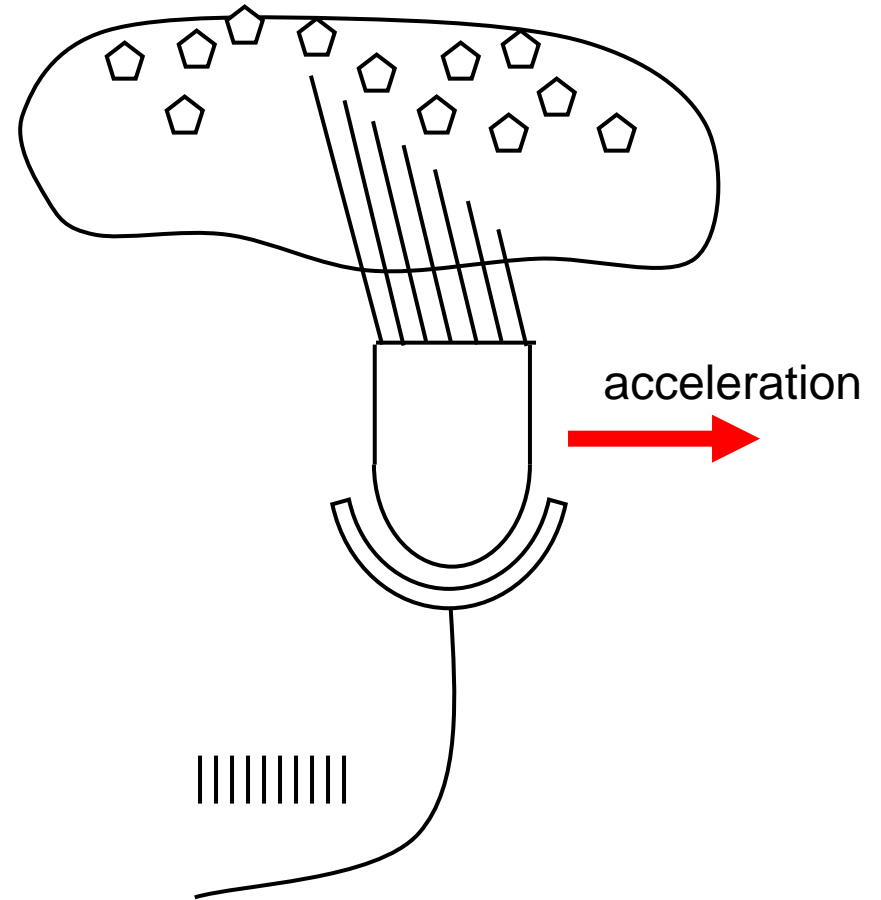
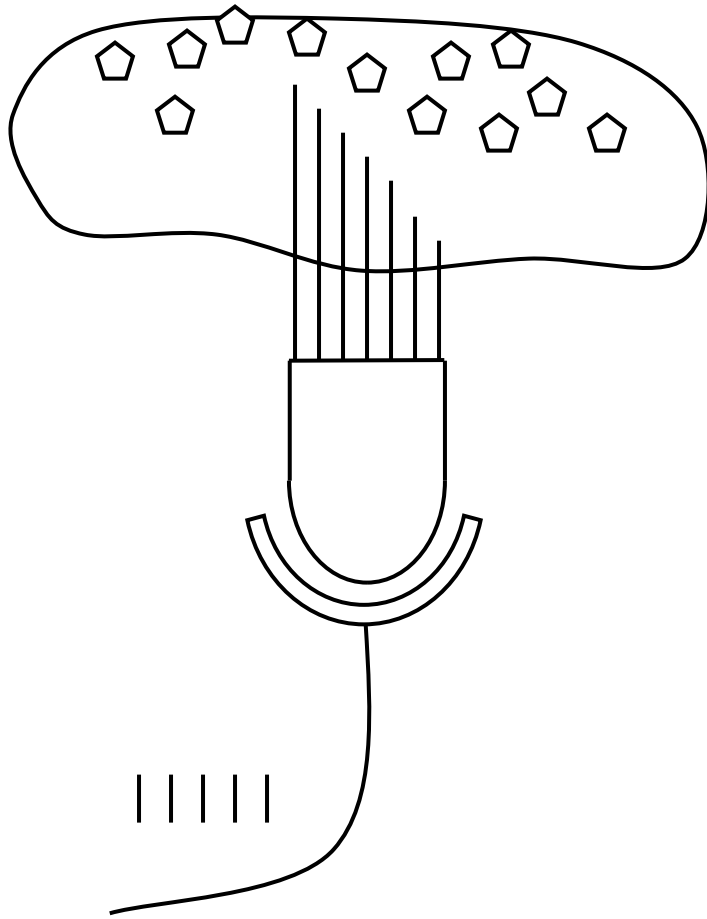

# Tilt translation dilemma



Equivalence principle:

An accelerometer can not distinguish between gravity and linear acceleration.

(1907)

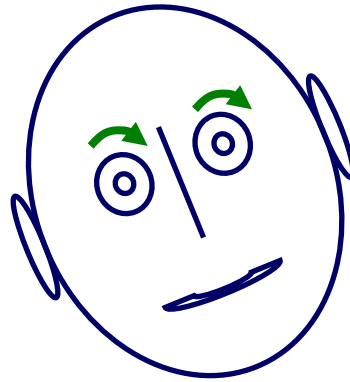
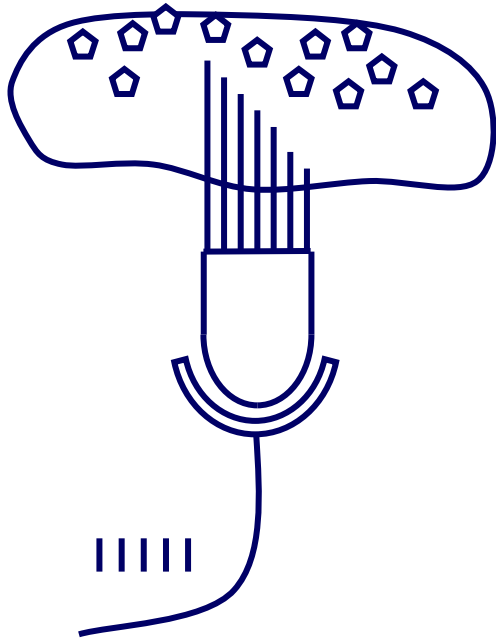
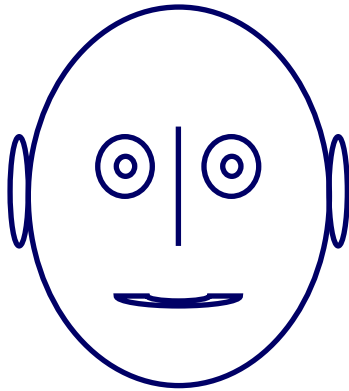

or

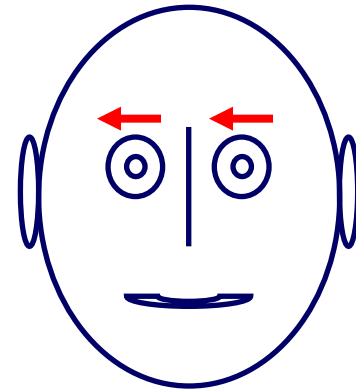

acc →

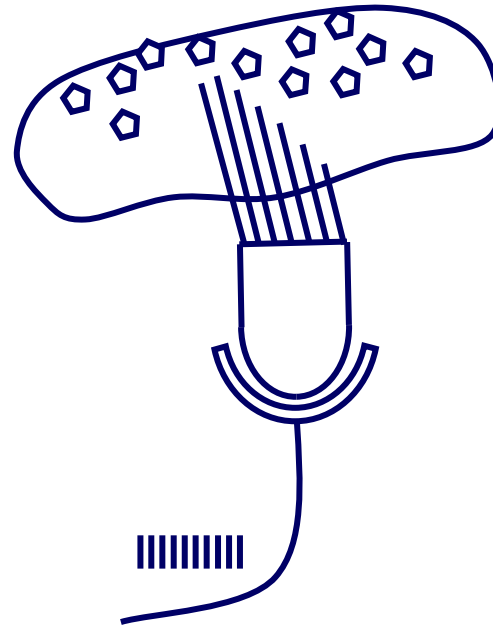

„tilt-translation  
dilemma“

# Horizontal translational VOR

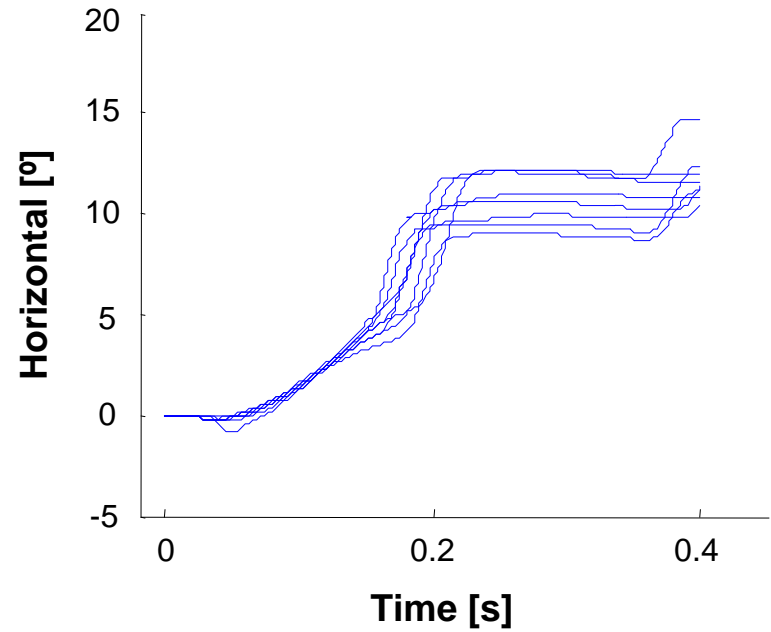
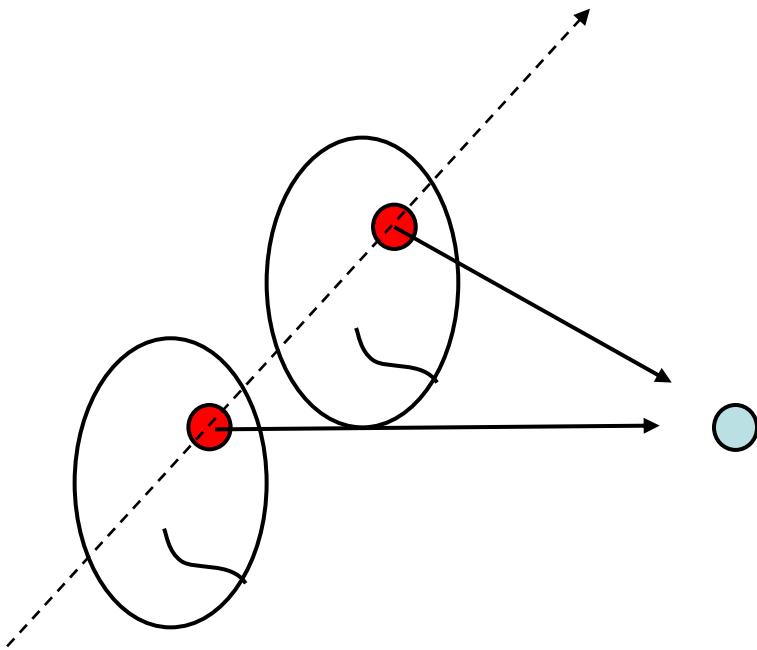

# Static ocular counterroll

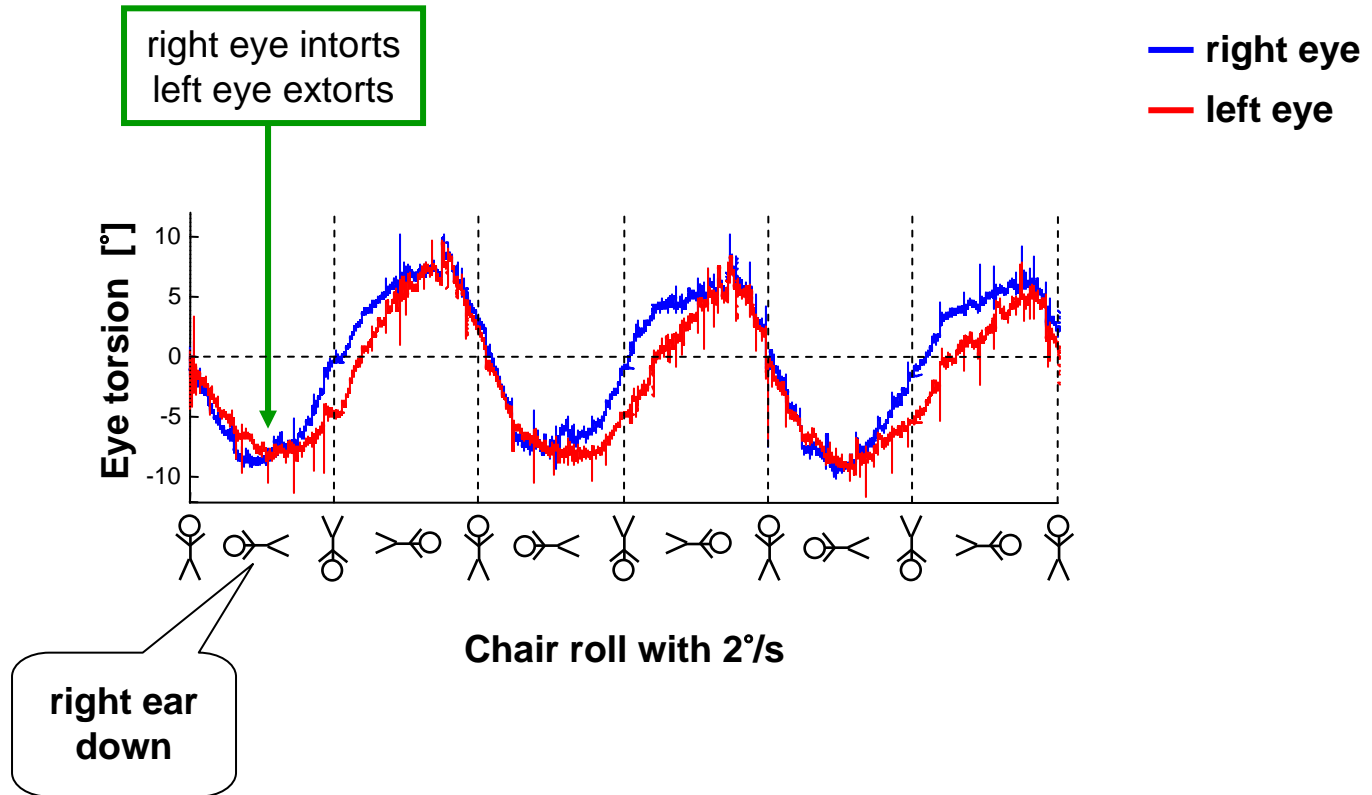

**Yaw rotation on  
office chair**

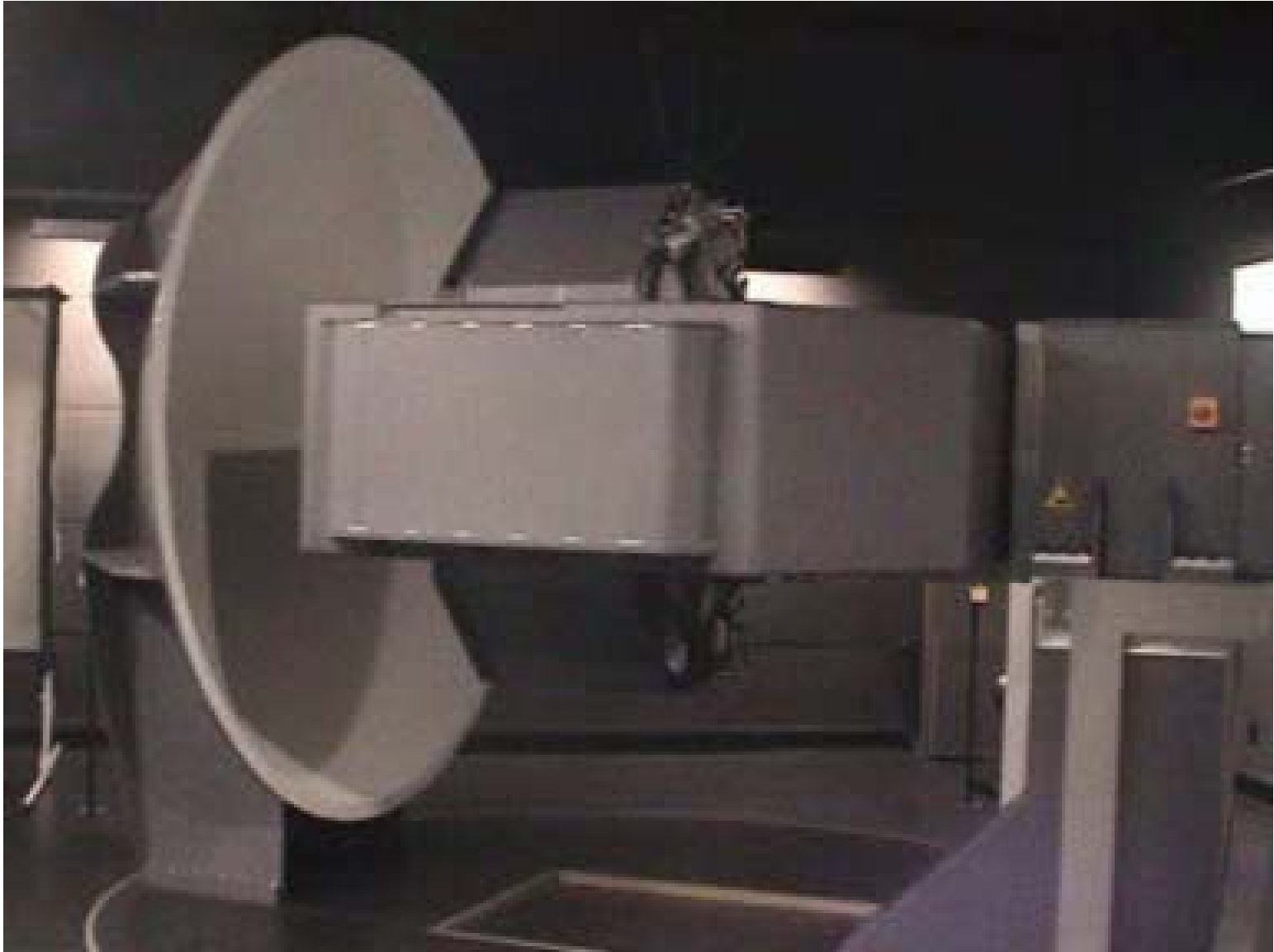

Coriolis-Experiment

# Right ear down → upright

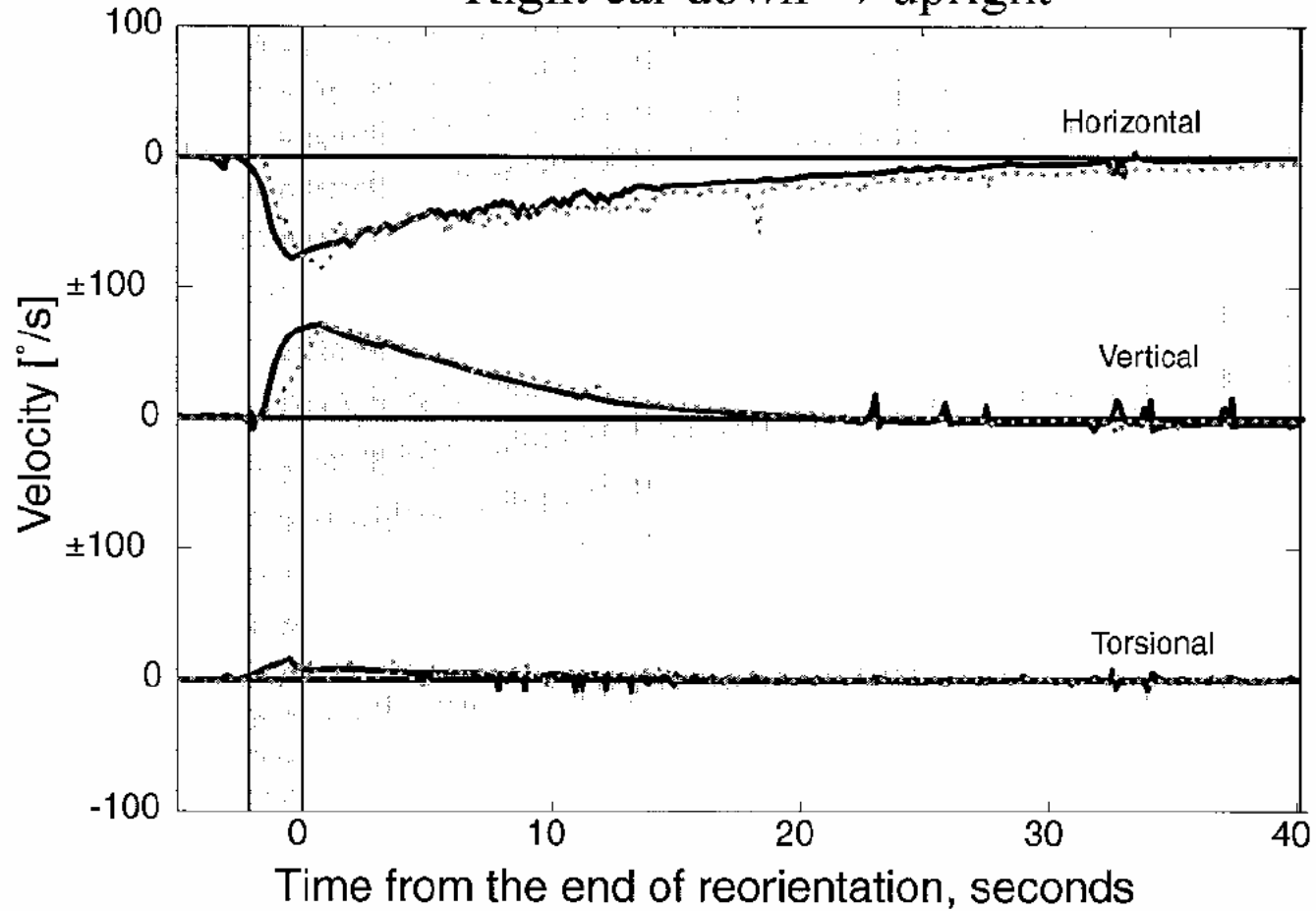

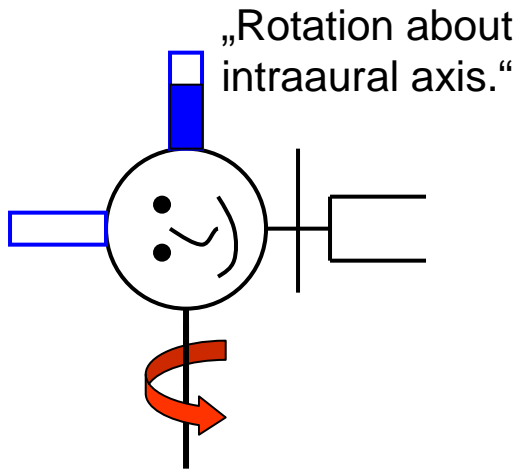
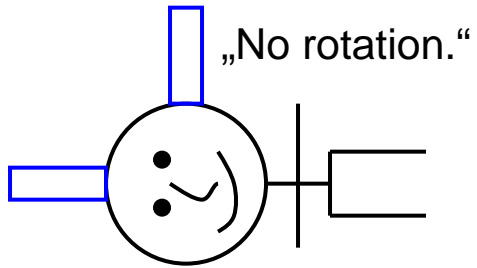

-----  
1 minute  
-----

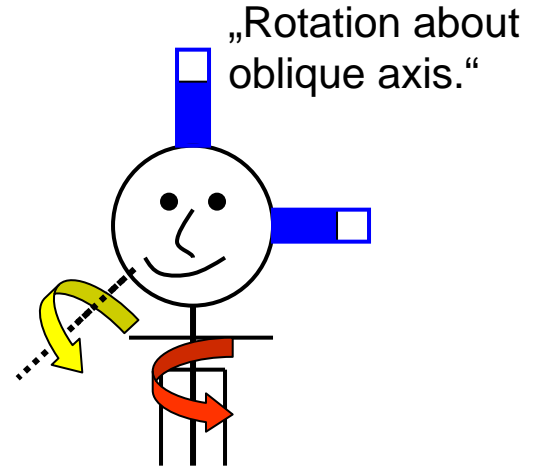

↑  
Tilt  
|

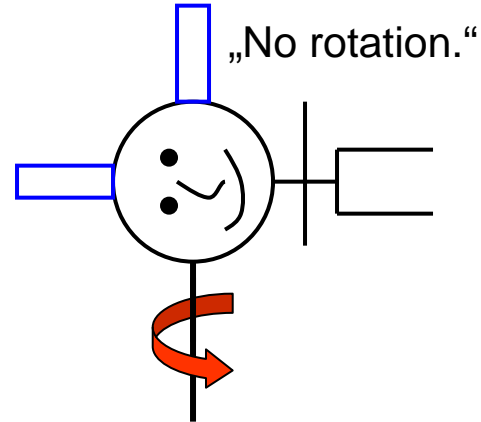

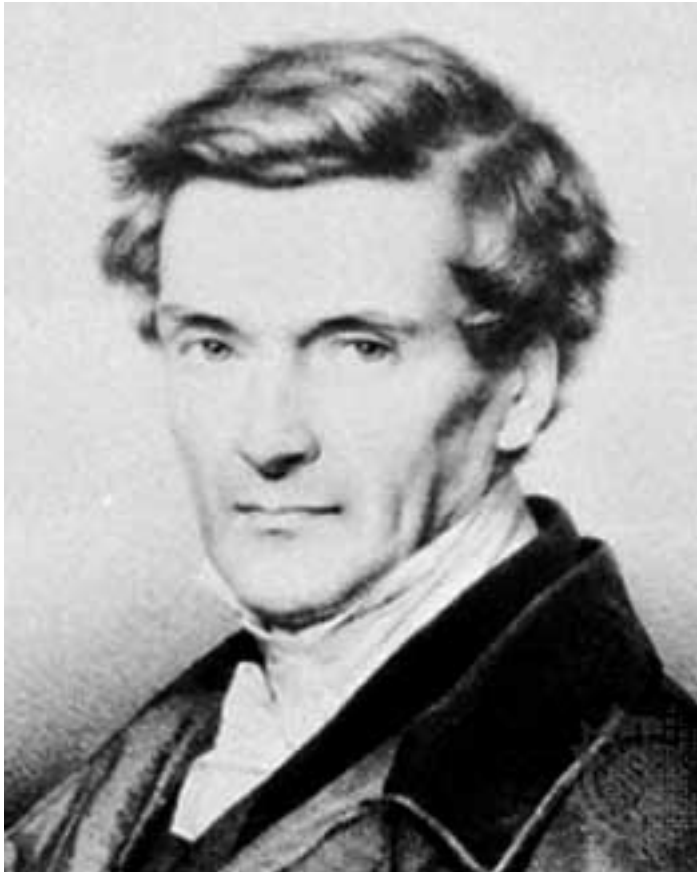

Gaspard-Gustave de Coriolis  
(Paris, 1792-1843)



Syd Mead

Thank you for your attention!